



## The Company

We are an established world force in the design and manufacture of instrumentation for industrial process control, flow measurement, gas and liquid analysis and environmental applications.

As a part of ABB, a world leader in process automation technology, we offer customers application expertise, service and support worldwide.

We are committed to teamwork, high quality manufacturing, advanced technology and unrivalled service and support.

The quality, accuracy and performance of the Company's products result from over 100 years experience, combined with a continuous program of innovative design and development to incorporate the latest technology.

The NAMAS Calibration Laboratory No. 0255 is just one of the ten flow calibration plants operated by the Company, and is indicative of our dedication to quality and accuracy.

BS ISO 9001:1994



Cert. No. Q05907

EN 29001 (ISO 9001)



Lenno, Italy – Cert. No. 9/90A

Stonehouse, U.K.



## Electrical Safety

This equipment complies with the requirements of CEI/IEC 61010-1:2001-2 'Safety Requirements for Electrical Equipment for Measurement, Control and Laboratory Use'. If the equipment is used in a manner NOT specified by the Company, the protection provided by the equipment may be impaired.

## Symbols

One or more of the following symbols may appear on the equipment labelling:

	<b>Warning</b> – Refer to the manual for instructions
	<b>Caution</b> – Risk of electric shock
	Protective earth (ground) terminal
	Earth (ground) terminal

	Direct current supply only
	Alternating current supply only
	Both direct and alternating current supply
	The equipment is protected through double insulation

Information in this manual is intended only to assist our customers in the efficient operation of our equipment. Use of this manual for any other purpose is specifically prohibited and its contents are not to be reproduced in full or part without prior approval of the Technical Publications Department.

### Health and Safety

To ensure that our products are safe and without risk to health, the following points must be noted:

1. The relevant sections of these instructions must be read carefully before proceeding.
2. Warning labels on containers and packages must be observed.
3. Installation, operation, maintenance and servicing must only be carried out by suitably trained personnel and in accordance with the information given.
4. Normal safety precautions must be taken to avoid the possibility of an accident occurring when operating in conditions of high pressure and/or temperature.
5. Chemicals must be stored away from heat, protected from temperature extremes and powders kept dry. Normal safe handling procedures must be used.
6. When disposing of chemicals ensure that no two chemicals are mixed.

Safety advice concerning the use of the equipment described in this manual or any relevant hazard data sheets (where applicable) may be obtained from the Company address on the back cover, together with servicing and spares information.

# CONTENTS

<b>1</b>	<b>TURBIDITY MEASUREMENT SYSTEMS</b> .....	<b>2</b>	<b>7</b>	<b>MAINTENANCE</b> .....	<b>29</b>
1.1	Introduction .....	2	7.1	Scheduled Maintenance .....	29
1.2	Turbidity Measurement Systems .....	3	7.1.1	Sensor Cleaning .....	29
<b>2</b>	<b>MECHANICAL INSTALLATION</b> .....	<b>5</b>	7.1.2	Calibration .....	29
2.1	Siting Requirements .....	5	7.1.3	Using Dry Calibration Standards .....	29
2.1.1	Analyzer .....	5	7.2	Calibration Checks .....	30
2.1.2	Sensor Unit (Models 7997 200 Series and 7997 300 only) .....	5	7.2.1	Procedure .....	30
2.2	Mounting the Transmitter Unit .....	6	7.3	Using Formazine Standard Solution .....	32
2.2.1	Wall-mounted Instrument .....	6	7.3.1	Preparing the Formazine Standard for Wet Calibration .....	32
2.2.2	Panel-mounted Instrument .....	7	7.4	Unscheduled Maintenance .....	33
2.3	Installing the Turbidity Sensor Unit .....	8	7.4.1	Transmitter Diagnostic messages .....	33
2.3.1	7997 201 and 7997 202 .....	9	7.4.2	Unstable or Erratic Readings .....	33
2.3.2	7997 200 Series and 7997 300 .....	9	7.4.3	Intermittent Short Term Spikes in Turbidity Readings .....	34
2.3.3	7997 400 Series .....	9	7.4.4	Care and Maintenance of Dry Calibration Standards .....	34
2.3.4	7997 405 .....	9	7.4.5	Determination of the Dry Standard Value for the 7997 300 and 400 Series Sensors .....	34
2.3.5	Flow Unit Dimensions .....	9	7.4.6	Converting 7997 202 Sensor to 7997 201 Sensor (with Integral Cleaning) .....	34
2.3.6	Mounting the Sensor .....	9	<b>8</b>	<b>SPECIFICATION</b> .....	<b>35</b>
2.3.7	Mounting the De-bubbler .....	11	<b>9</b>	<b>SPARES</b> .....	<b>38</b>
2.3.8	Set Up Procedure for Optional De-bubbler .....	11	9.1	Model 7997 200 Series .....	38
<b>3</b>	<b>ELECTRICAL CONNECTIONS</b> .....	<b>12</b>	9.2	Model 7997 300 .....	38
3.1	Access to Terminals .....	12	9.3	Model 7997 400 Series .....	39
3.1.1	Wall-mounted Instrument .....	12	9.4	Calibration Standards .....	39
3.1.2	Panel-mounted Instrument .....	12	9.5	De-bubbler .....	39
3.2	Connections, General .....	13	<b>APPENDIX A</b> .....	<b>40</b>	
3.2.1	Relay Contact Protection and Interference Suppression .....	13	A1	Principle of Operation .....	40
3.3	Wall-mounted Instrument Connections .....	14	A1.1	Nephelometric .....	40
3.4	Panel-Mounted Instrument Connections .....	15	A1.2	Absorption .....	40
3.5	Selecting the Mains Voltage .....	16	A1.3	Calibration .....	40
3.5.1	Wall-mounted Instrument .....	16	<b>APPENDIX B</b> .....	<b>41</b>	
3.5.2	Panel-mounted Instrument .....	16	B1	Determination of the Correction Factor .....	41
3.6	Turbidity Unit Connection Box .....	17	B1.1	Definition .....	41
3.7	Connections for 7997 405 .....	17	B1.2	Method .....	41
<b>4</b>	<b>CONTROLS AND DISPLAYS</b> .....	<b>18</b>	<b>APPENDIX C</b> .....	<b>42</b>	
4.1	Displays .....	18	C1	7997 100 Sensors .....	42
4.2	Control Familiarization .....	18	C1.1	Description .....	42
<b>5</b>	<b>START UP AND OPERATION</b> .....	<b>19</b>	C1.2	Flow Unit Dimensions .....	42
5.1	Instrument Start-up .....	19	C1.3	Wall-mounted Instrument Connections .....	43
5.2	Operation – Turbidity Measurement Mode .....	19	C1.4	Panel-mounted Instrument Connections .....	44
5.2.1	Operating Page .....	19	C1.5	Turbidity Unit Connection Box .....	45
5.2.2	Calibration Page .....	20	C1.6	Maintenance .....	46
<b>6</b>	<b>PROGRAMMING &amp; ELECTRICAL CALIBRATION</b> ....	<b>22</b>	C1.7	Spares .....	46
6.1	Access to Secure Parameters .....	23	C1.8	Specification .....	46
6.2	Language Page .....	23			
6.3	Set Up Parameter Page .....	23			
6.4	Set Up Outputs Page .....	25			
6.5	Electrical Calibration .....	27			
6.5.1	Equipment Required .....	27			
6.6	Preparation .....	27			
6.7	Electrical Calibration Page .....	28			

# 1 TURBIDITY MEASUREMENT SYSTEMS

## 1.1 Introduction

An ABB Turbidity System comprises a 4670 wall-mounted, or 4675 panel-mounted, analyzer, together with one of five sensor models 7997 200 to 7997 405.

The analyzer provides the operator interface and communications to other devices.

The signal from the sensing system is converted by the analyzer, and the information is presented on a large, custom-designed, easy-to-read, backlit liquid crystal display (LCD).

The analyzers can be programmed to work with any of the 7997 sensors, and the operating range can also be configured to meet users' requirements.

Available in a wall-mount or 1/4 DIN panel-mount version, the analyzer is protected to IP66, ensuring reliable operation in the most demanding situations. The same level of protection is maintained during programming and calibration.

Details of the individual sensors are given in Table 1.1 below:

System No.	Sensor No.	Principle of Sensor	Type of Sensor	Minimum Range	Maximum Range
467x 20y	7997 200	Nephelometric	Flow	0 to 25NTU	0 to 250NTU
457x 21y	7997 201	Nephelometric	Flow	0 to 1NTU	0 to 30NTU
467x 22y	7997 202	Nephelometric	Flow (no cleaner)	0 to 1NTU	0 to 30NTU
467x 30y	7997 300	Absorption	Flow	0 to 100FTU	0 to 500FTU
467x 40y	7997 400	Absorption	1m Dip	0 to 100FTU	0 to 2000FTU
467x 41y	7997 401	Absorption	2m Dip	0 to 100FTU	0 to 2000FTU
467x 45y	7997 405	Absorption	Flow	0 to 100FTU	0 to 2000FTU

**Notes:** x denotes the transmitter mounting: 0 = wall  
5 = panel

y denotes the language: 1 = English  
2 = German  
3 = French  
4 = Spanish

**Table 1.1 Coding System**

1.2 Turbidity Measurement Systems – Figs. 1.1A and 1.1B

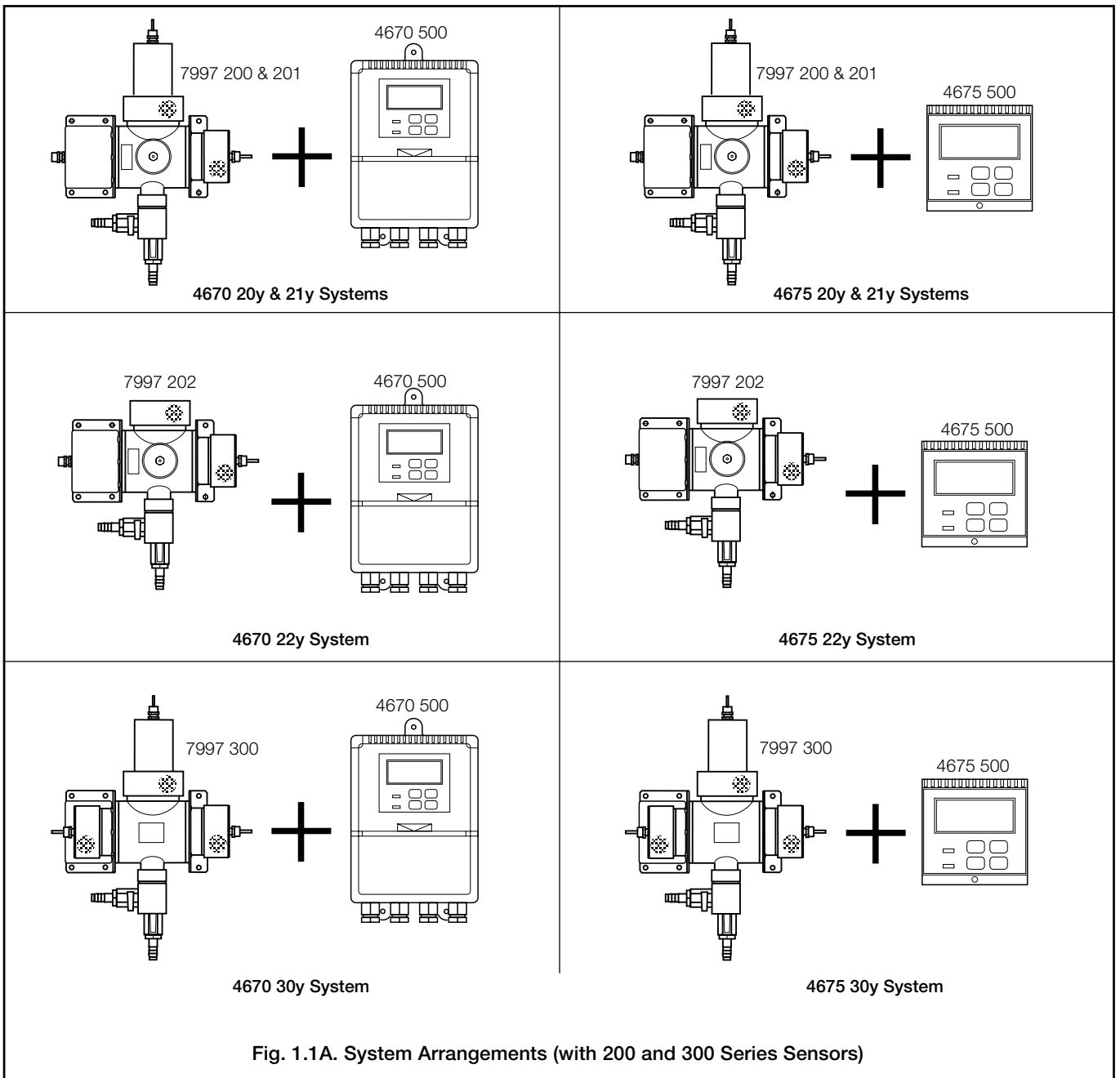

...1 MEASUREMENT SYSTEMS

...1.2 Turbidity Measurement Systems – Figs. 1.1A and 1.1B

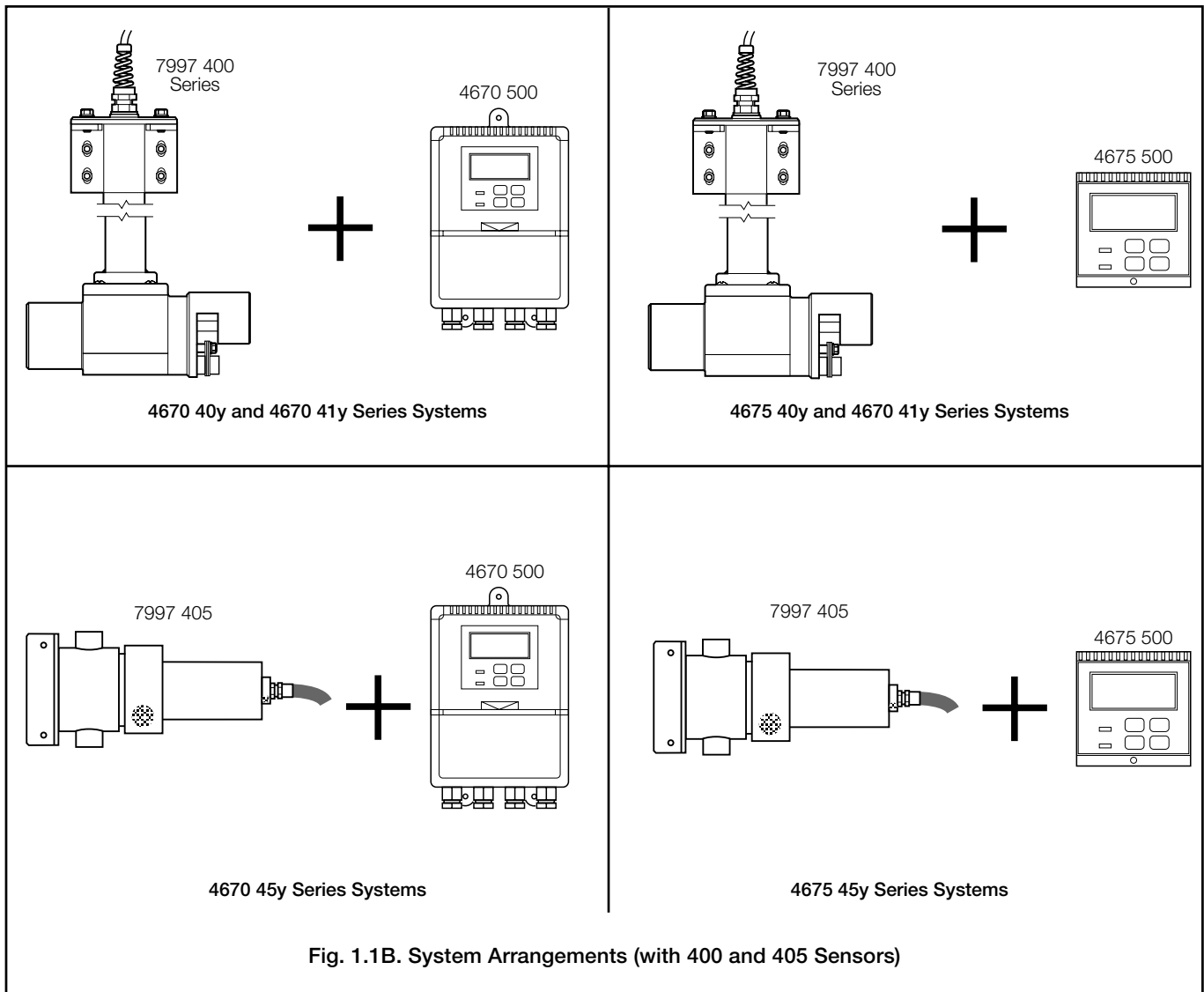

## 2 MECHANICAL INSTALLATION

### 2.1 Siting Requirements

#### 2.1.1 Analyzer – Fig. 2.1

**Caution.**

- Mount in a location free from excessive vibration.
- Mount away from harmful vapors and dripping fluids.

**Information.** It is preferable to mount the instrument at eye level, allowing an unrestricted view of the front panel displays and controls

#### 2.1.2 Sensor Unit – Fig. 1.1A (Models 7997 200 Series and 7997 300 only)

For easy removal of sensor unit for maintenance if required, allow sufficient clearance of 200 mm (7.9 in.) all around – see Section 2.3.1 for overall dimensions of units.

**Note.** For ease of use it is recommended that the maximum height of the sensor unit above floor level should not exceed chest level. This ensures ease of access during calibration and cleaning procedures.

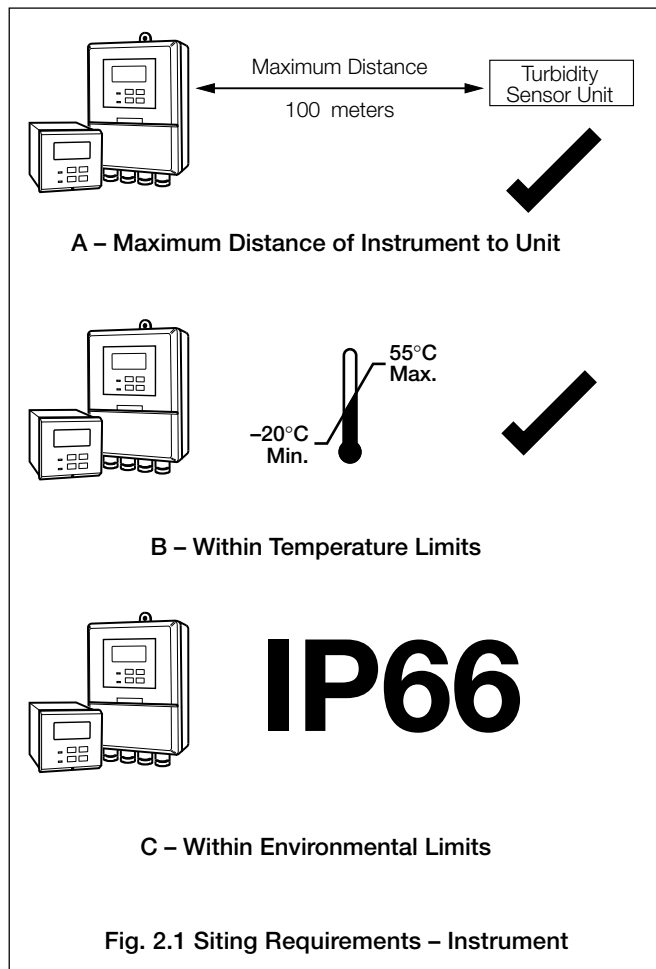

## ...2 MECHANICAL INSTALLATION

### 2.2 Mounting the Transmitter Unit

#### 2.2.1 Wall-mounted Instrument – Figs. 2.2 and 2.3

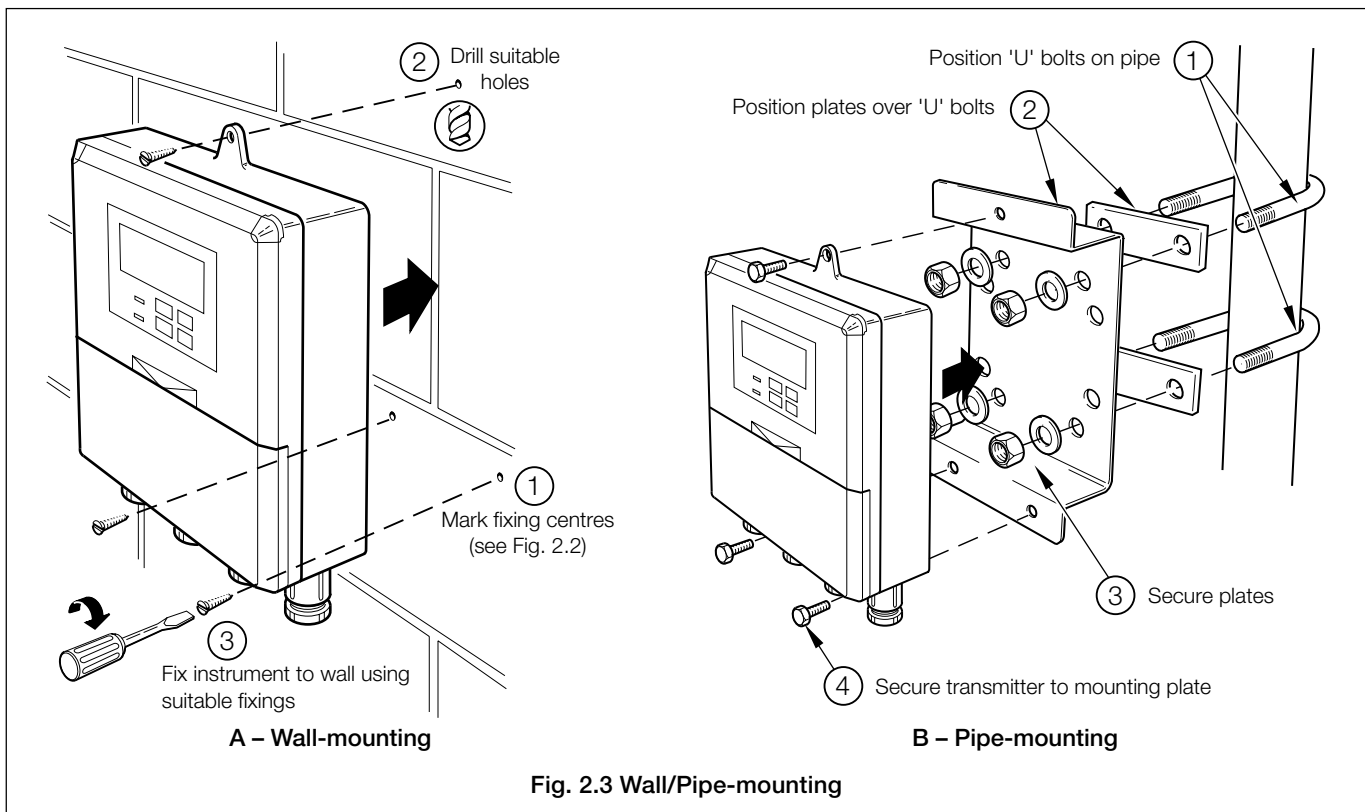
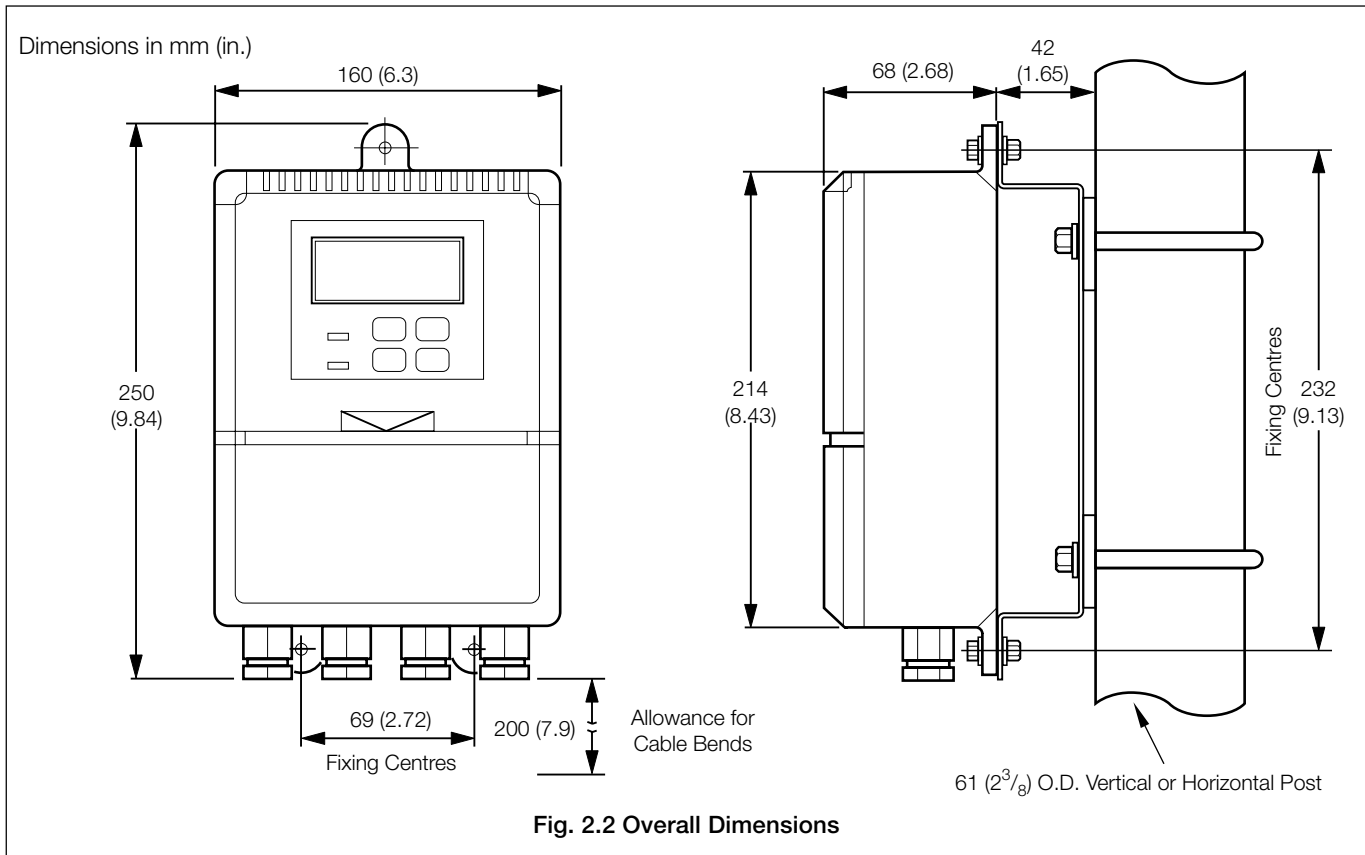



2.2.2 Panel-mounted Instrument – Figs. 2.4 and 2.5

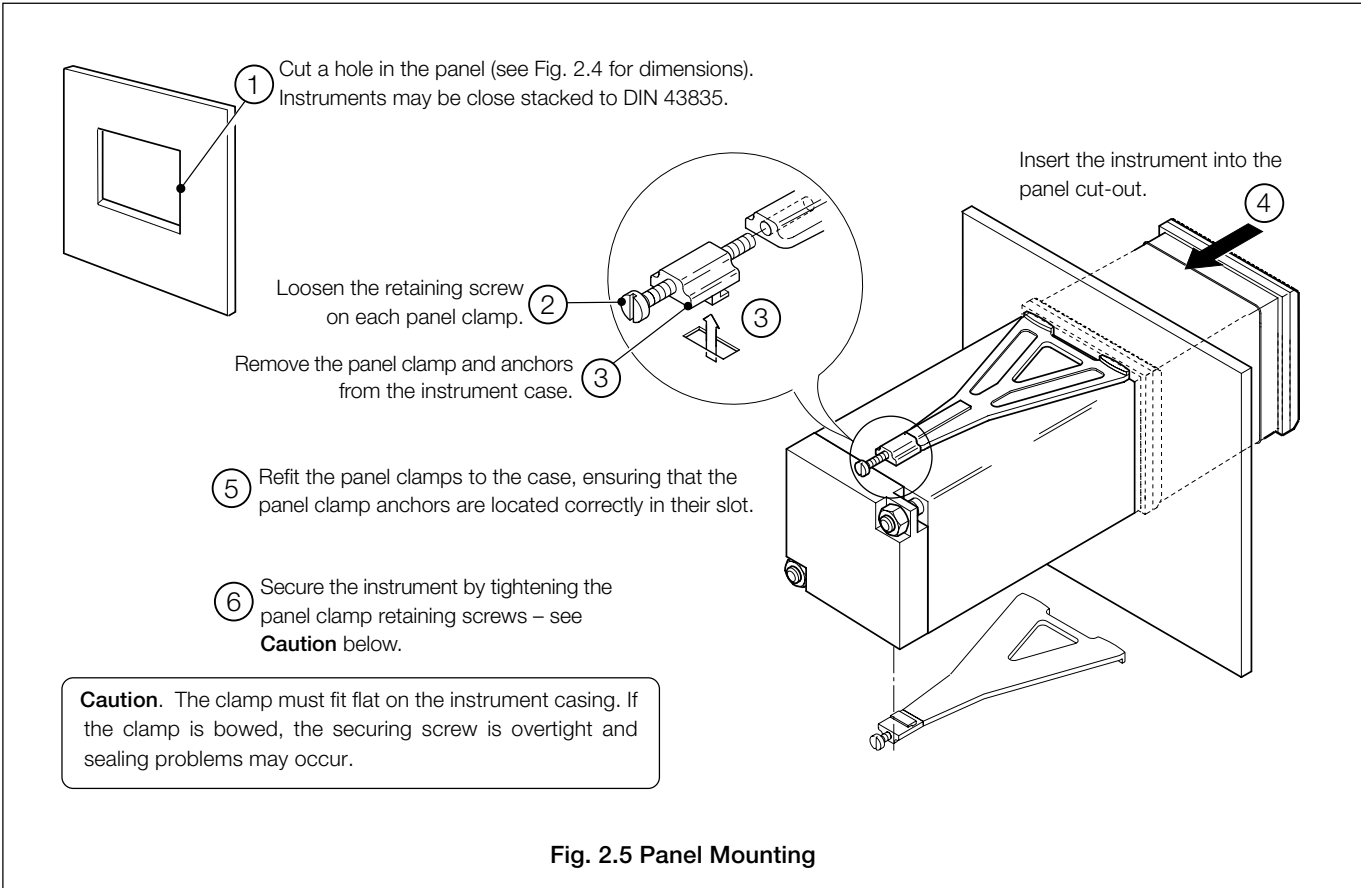
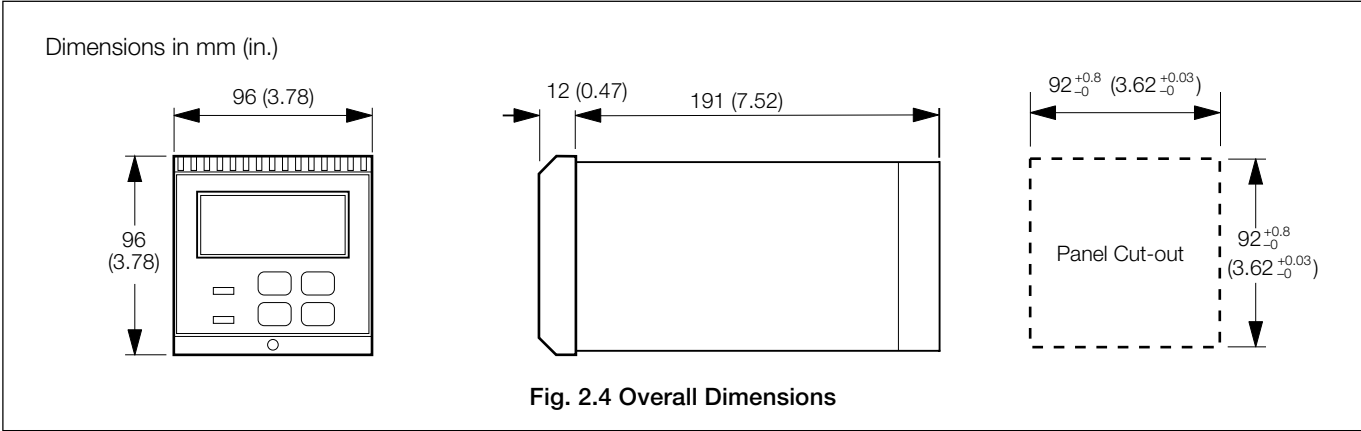

2.3 Installing the Turbidity Sensor Unit – Table 1.1 and Fig. 2.6

Systems and sensors are shown in Table 1.1. The main components of each unit are identified in Fig. 2.7.

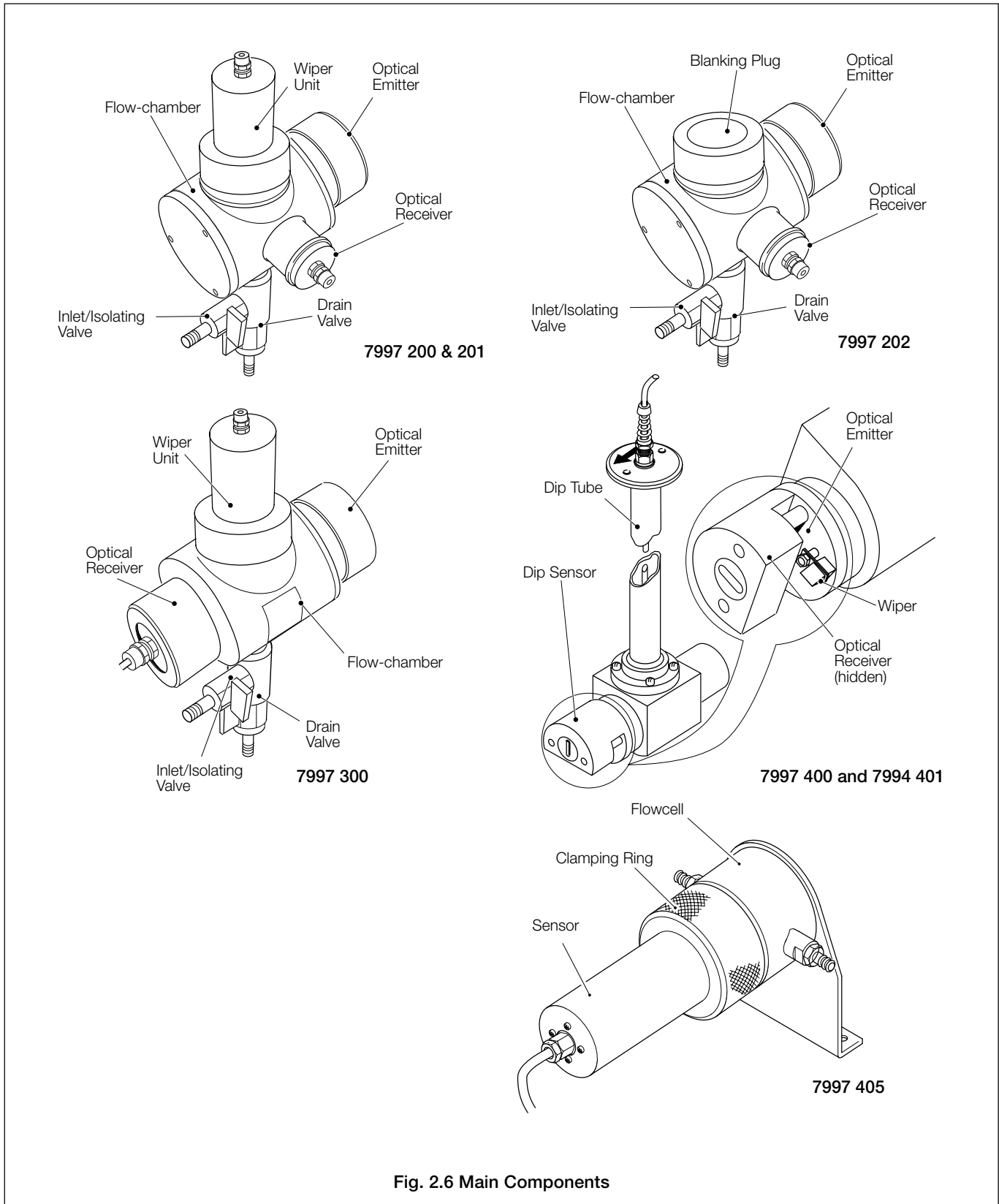

Fig. 2.6 Main Components

**2.3.1 7997 201 and 7997 202**

These sensors are designed to operate at very low turbidity values of less than 0.1 NTU. At these values it is most important that additional sources of light scattering, such as gas bubbles in the sample, are eliminated. In this case an optional debubbler (part number 7997 500) is available to eliminate the effect of gas bubbles.

**2.3.2 7997 200 Series and 7997 300**

The flowrate should be maintained at a reasonable level (i.e. 0.5 l min<sup>-1</sup>) to prevent possible solids settling out in the pipework. If this becomes a problem higher flowrates may be required. The maximum flow rate of 6.0 l min<sup>-1</sup> should not be exceeded.

**2.3.3 7997 400 Series**

The dip sensor should be mounted in a position where a representative sample is always monitored (i.e. not in an obscure corner away from the main flow path). The dip tube should not be totally submerged, but the sensor assembly at the end of the dip tube must always be in the sample despite any change in liquid level, to enable a correct turbidity measurement to be achieved.

In applications with excessive flowrate, the sensor should be mounted with the arrow on the top of the dip tube, in line with the direction of flow – see Fig. 2.6.

**2.3.4 7997 405**

The flowrate should be maintained at a reasonable level (i.e. 0.5 l min<sup>-1</sup>) to prevent possible solids settling out in the pipework. If this becomes a problem higher flowrates may be required. The maximum flow rate of 6.0 l min<sup>-1</sup> should not be exceeded.

**2.3.5 Flow Unit Dimensions – Table 2.1**

Model	Height	Width	Depth
7997/200	400.0mm	294.5mm	329.0mm
7997/300	400.0mm	294.5mm	160.0mm
7997/400	93.5mm	82.0mm	212.5mm
7997/405	approx. 300mm (see <b>Note</b> below)	135.0mm	135.0mm

**Note.** 240mm + 30mm for the cable gland + approximately 30mm for the bracket.

**Table 2.1 Overall Dimensions in mm**

**2.3.6 Mounting the Sensor – Figs. 2.7 (7997 200 Series and 300), 2.8 (7997 200 Series), 2.9 (7997 300), 2.10 (7997 400 Series) and 2.11 (7997 405)**

Mount the sensor in the attitude shown in the appropriate illustration using the bracket(s) provided, where required. Connect the sample and drain tubes.

**Important Note.** Mount units within 5° of their vertical axes.

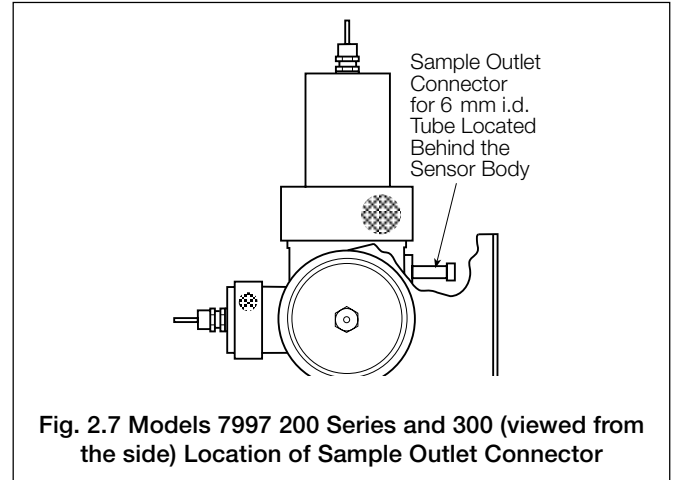

**Fig. 2.7 Models 7997 200 Series and 300 (viewed from the side) Location of Sample Outlet Connector**

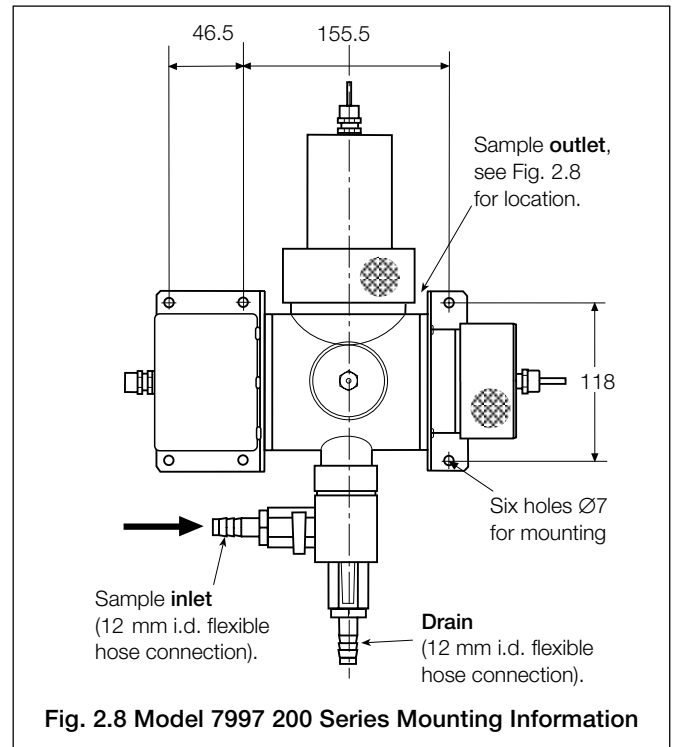

**Fig. 2.8 Model 7997 200 Series Mounting Information**

...2 MECHANICAL INSTALLATION

...2.3.6 Mounting the Sensor – Figs. 2.7 (7997 200 Series and 300), 2.8 (7997 200 Series), 2.9 (7997 300), 2.10 (7997 400 Series) and 2.11 (7997 405)

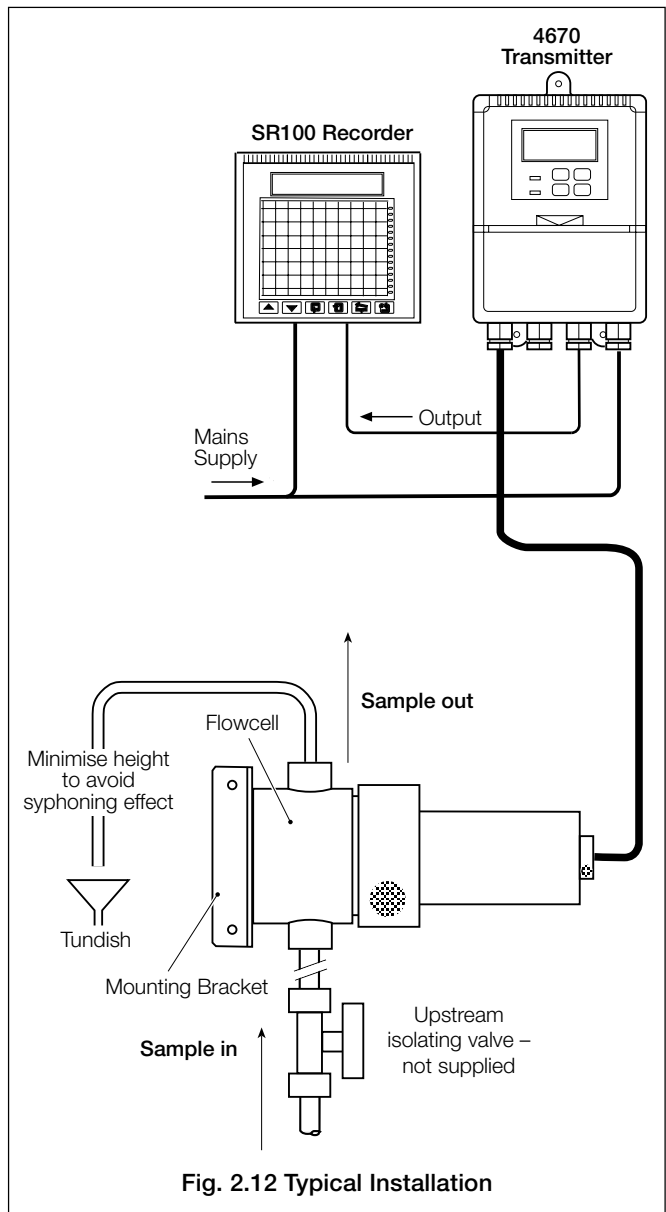
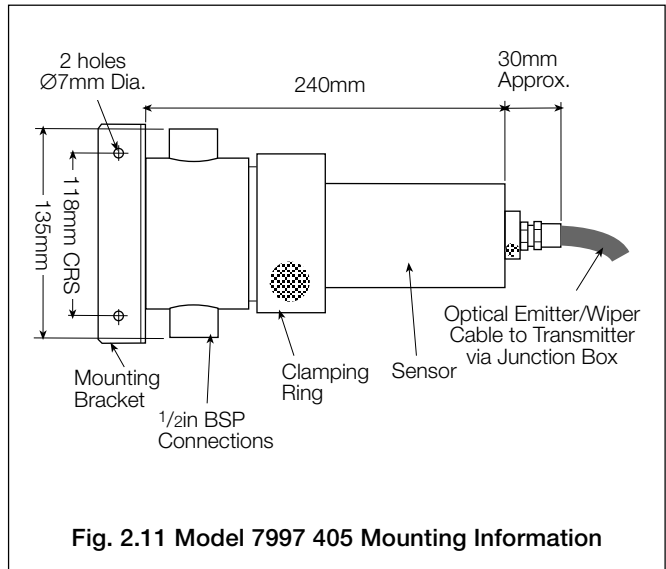
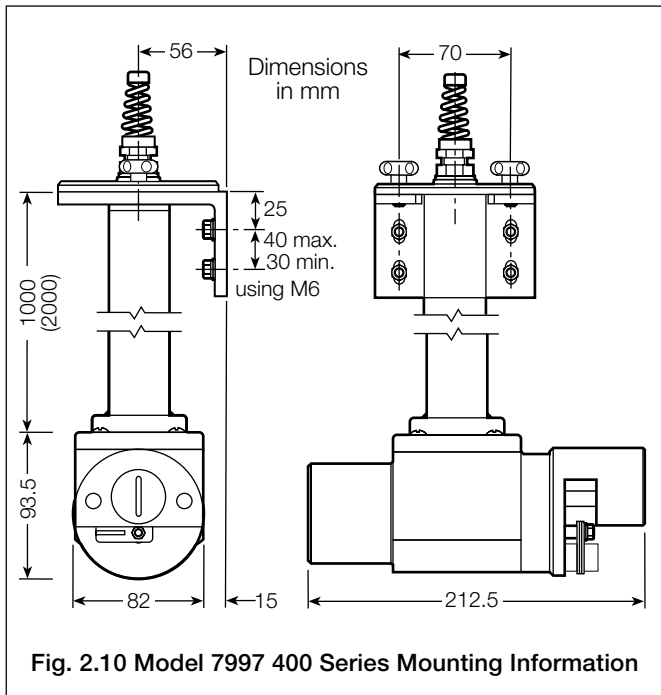
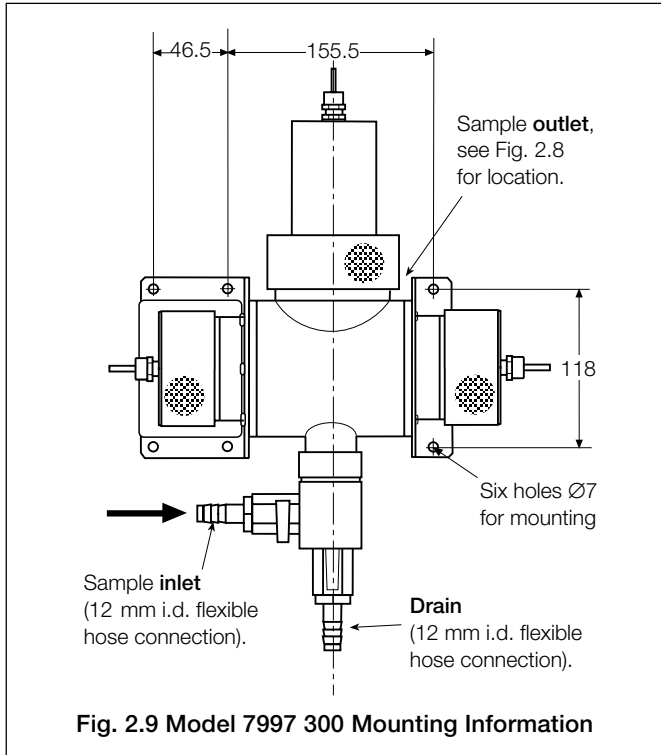

2.3.7 Mounting the De-bubbler – Fig. 2.13

For use with the Model 7997 201.

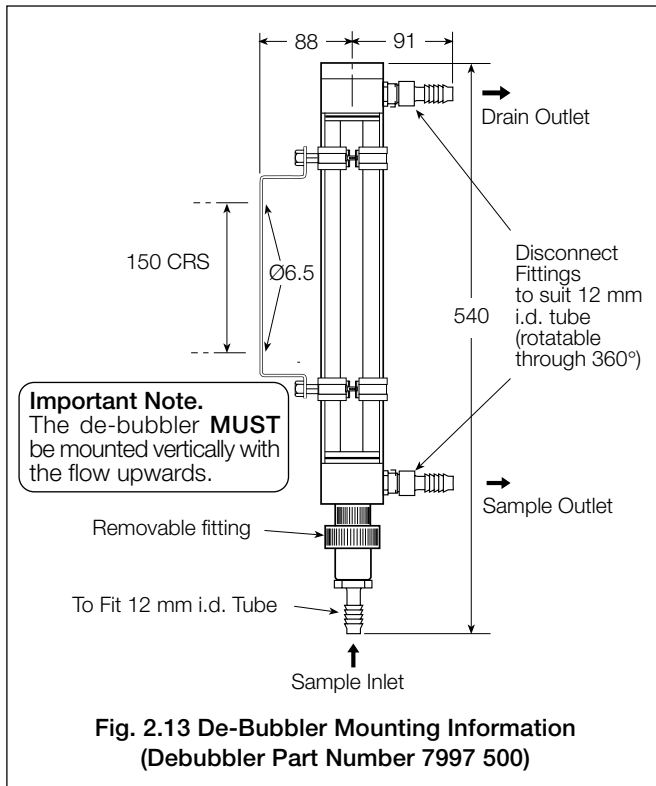

2.3.8 Set Up Procedure for Optional De-bubbler – Fig. 2.14

With a system which includes a de-bubbler, set it up as follows:

- 1) Open the 'sample in' isolating valve (A) such that the overflow from the de-bubbler is at a minimum.
- 2) Adjust the sample flow through the turbidity system using the regulating valve (B).

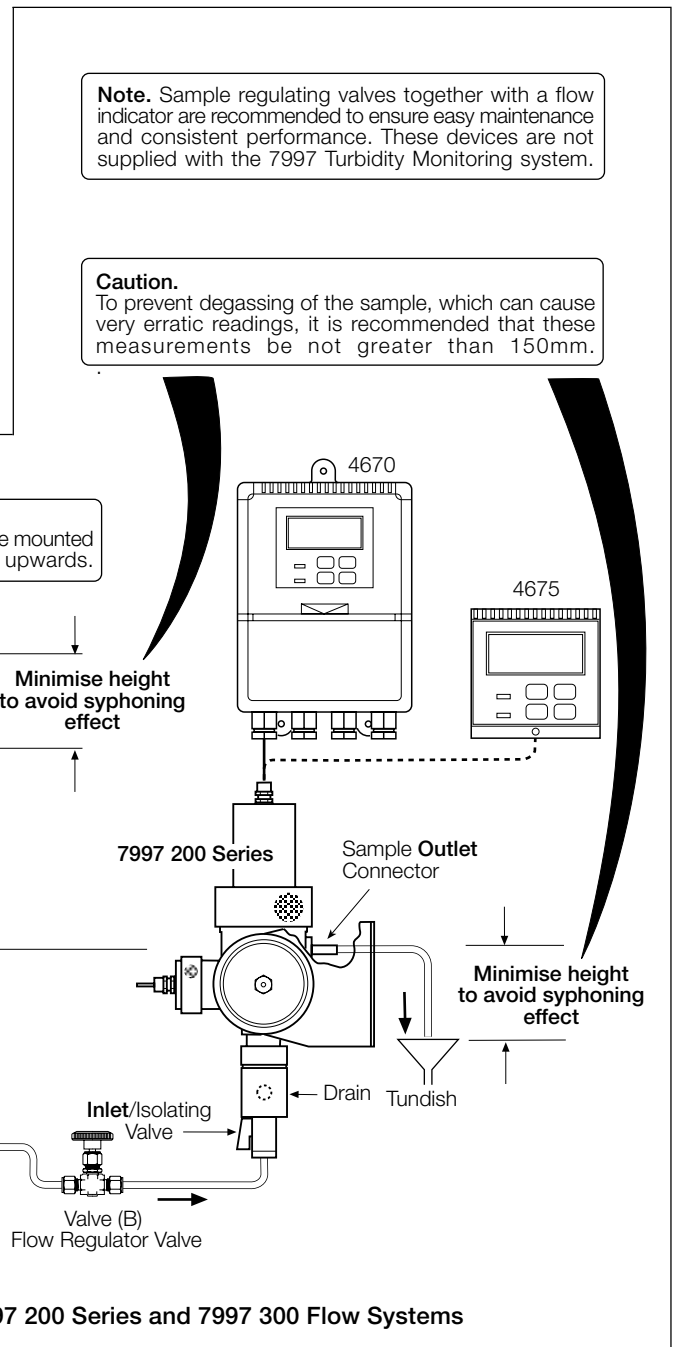

### 3 ELECTRICAL CONNECTIONS

#### Warning.

- Although certain instruments are fitted with internal fuse protection, a suitably rated external protection device, e.g. fuse or miniature circuit breaker (m.c.b.), must also be fitted by the installer.
- Before making any connections, ensure that the power supply, any high voltage-operated control circuits and high common mode voltage are switched off.

#### 3.1 Access to Terminals

##### 3.1.1 Wall-mounted Instrument – Fig. 3.1

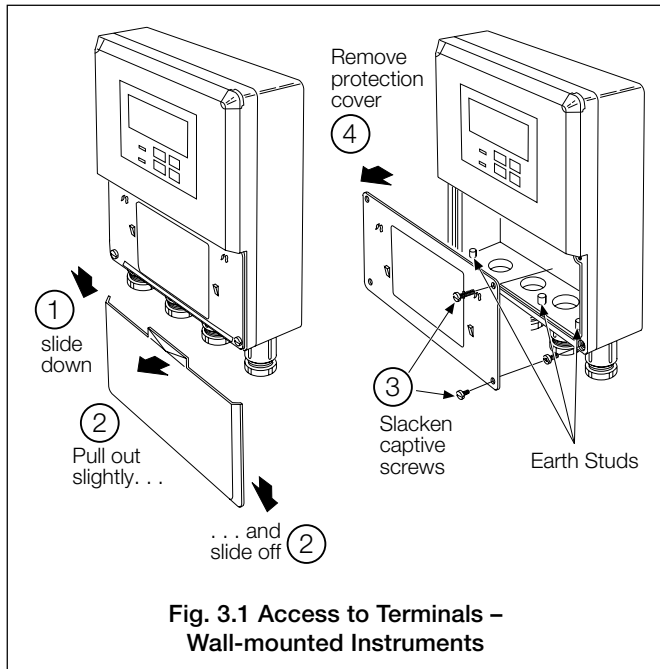

##### 3.1.2 Panel-mounted Instrument – Fig. 3.2

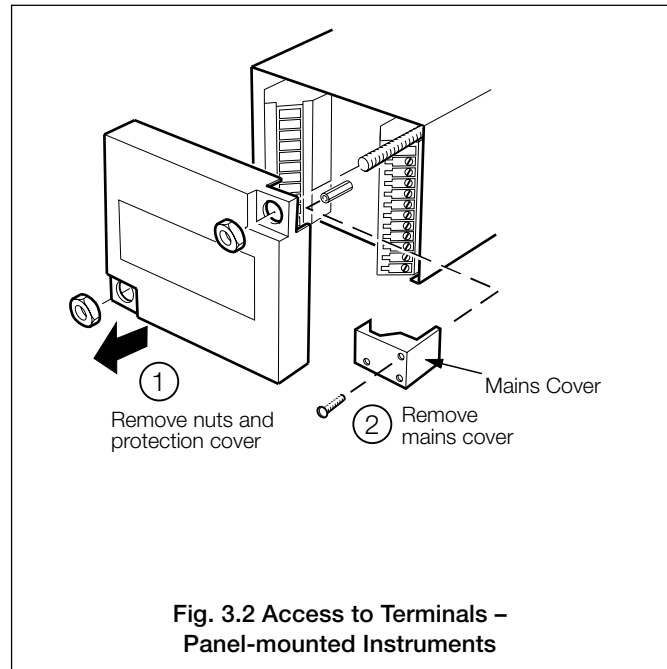

### 3.2 Connections, General

**Warning.** The power supply earth (ground) **must** be connected to ensure safety to personnel, reduction of the effects of RFI and correct operation of the power supply interference filter.

#### Information.

- **Earthing (grounding)** – stud terminal(s) is fitted to the transmitter case for bus-bar earth (ground) connection – see Fig. 3.1 or 3.5.
- **Cable lengths** – The cable length between the turbidity sensor unit and the electronics unit is provided as ordered, and terminated at the sensor unit. The cable can be shortened or lengthened as appropriate to the installation.
- **Cable routing** – always route the signal cable and mains-carrying/relay cables separately, ideally in earthed (grounded) metal conduit.

Ensure that the cables enter the transmitter through the glands nearest the appropriate screw terminals and are short and direct. Do not tuck excess cable into the terminal compartment.

- **Cable glands & conduit fittings** – ensure a moisture-tight fit when using cable glands, conduit fittings and blanking plugs/bungs (M20 holes). The M16 glands ready-fitted to wall-mounted instruments accept cable of between 4 and 7 mm diameter.
- **Relays** – the relay contacts are voltage-free and must be appropriately connected in series with the power supply and the alarm/control device which they are to actuate. Ensure that the contact rating is not exceeded. Refer also to Section 3.2.1 for relay contact protection details when the relays are to be used for switching loads.
- **Retransmission output** – Do not exceed the maximum load specification for the selected current retransmission range – see **SPECIFICATION**, Section 8.

Since the retransmission output is isolated the –ve terminal **must** be connected to earth (ground) if connecting to the isolated input of another device.

#### 3.2.1 Relay Contact Protection and Interference Suppression – Fig. 3.3

If the relays are used to switch loads on and off, the relay contacts can become eroded due to arcing. Arcing also generates radio frequency interference (RFI) which can result in instrument malfunction and incorrect readings. To minimize the effects of RFI, arc suppression components are required; resistor/capacitor networks for AC applications or diodes for DC applications. These components can be connected either across the load or directly across the relay contacts. On 4600 Series instruments the RFI components must be fitted to the relay terminal block along with the supply and load wires – see Fig 3.3

For **AC applications** the value of the resistor/capacitor network depends on the load current and inductance that is switched. Initially, fit a 100R/0.022  $\mu$  FRC suppressor unit (part no. B9303) as shown in Fig. 3.3A. If the instrument malfunctions (incorrect readings) or resets (display shows 88888) the value of the RC network is too low for suppression – an alternative value must be used. If the correct value cannot be obtained, contact the manufacturer of the switched device for details on the RC unit required.

For **DC applications** fit a diode as shown in Fig. 3.3B. For general applications use an IN5406 type ( 600 V peak inverse voltage at 3A – part no. B7363).

**Note.** For reliable switching the minimum voltage must be greater than 12 V and the minimum current greater than 100 mA.

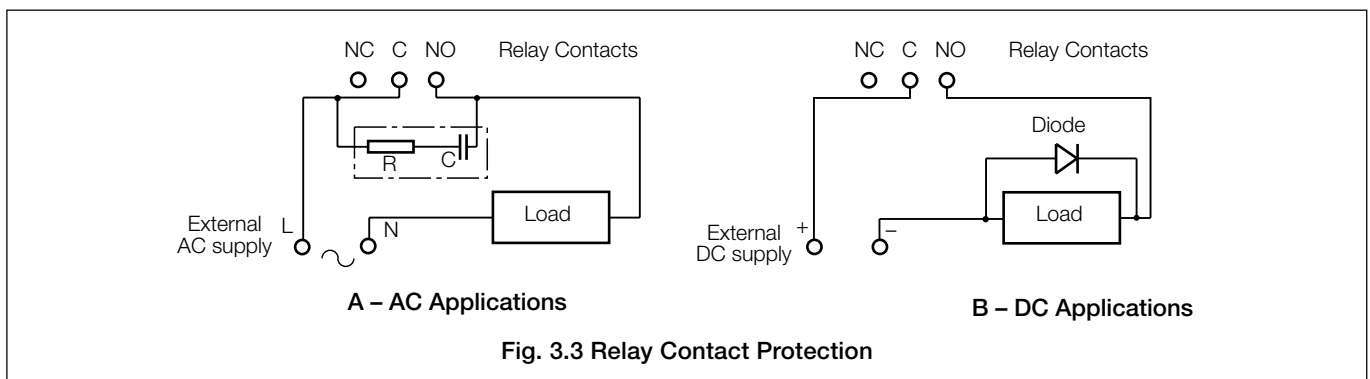

...3 ELECTRICAL CONNECTIONS

3.3 Wall-mounted Instrument Connections – Fig. 3.4 and Table 3.1

**Note.** Refer to Fig. 3.1 for Access to Terminals.

**Caution.** Slacken terminal screws fully before making connections.

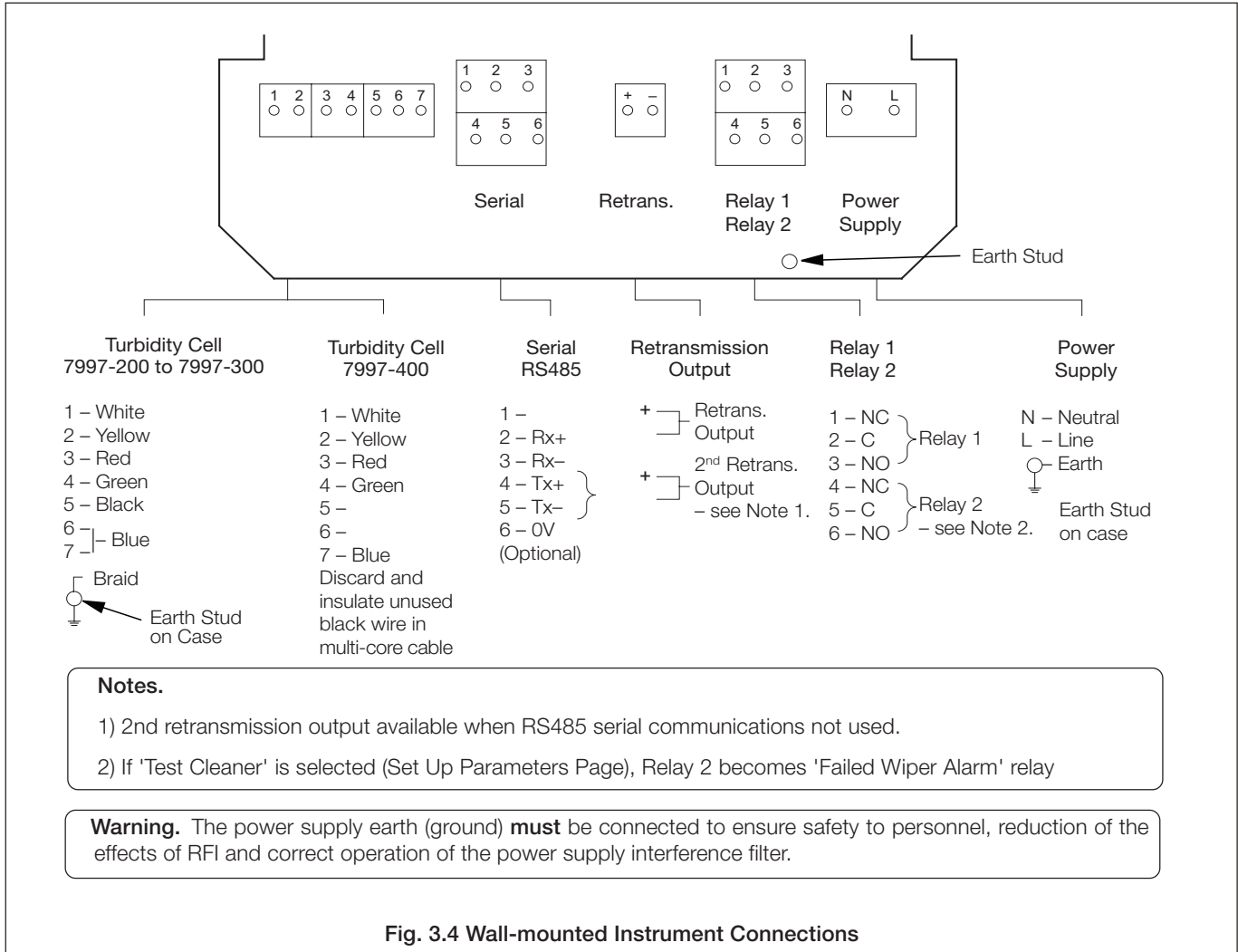

Fig. 3.4 Wall-mounted Instrument Connections

Mounting	Terminal Number						
	1	2	3	4	5	6	7
Wall	1	2	3	4	5	6	7
Panel	12	11	10	9	8	7	6
	Cleaner initiate pulse	+12V switched emitter supply	+12V cleaner/receiver supply	Signal input	Cleaner* Detect signal		0V common

\* Not used on 7997 400

Table 3.1 4600 Series Transmitter Input Connections

\* Link (Not on 7997-400/410 sensors)



3.4 Panel-Mounted Instrument Connections – Fig. 3.5 and Table 3.1

**Note.** Refer to Fig. 3.2 for Access to Terminals.

**Important Note.** To locate wires in the terminal blocks, slacken the terminal screws until full clearance is achieved.

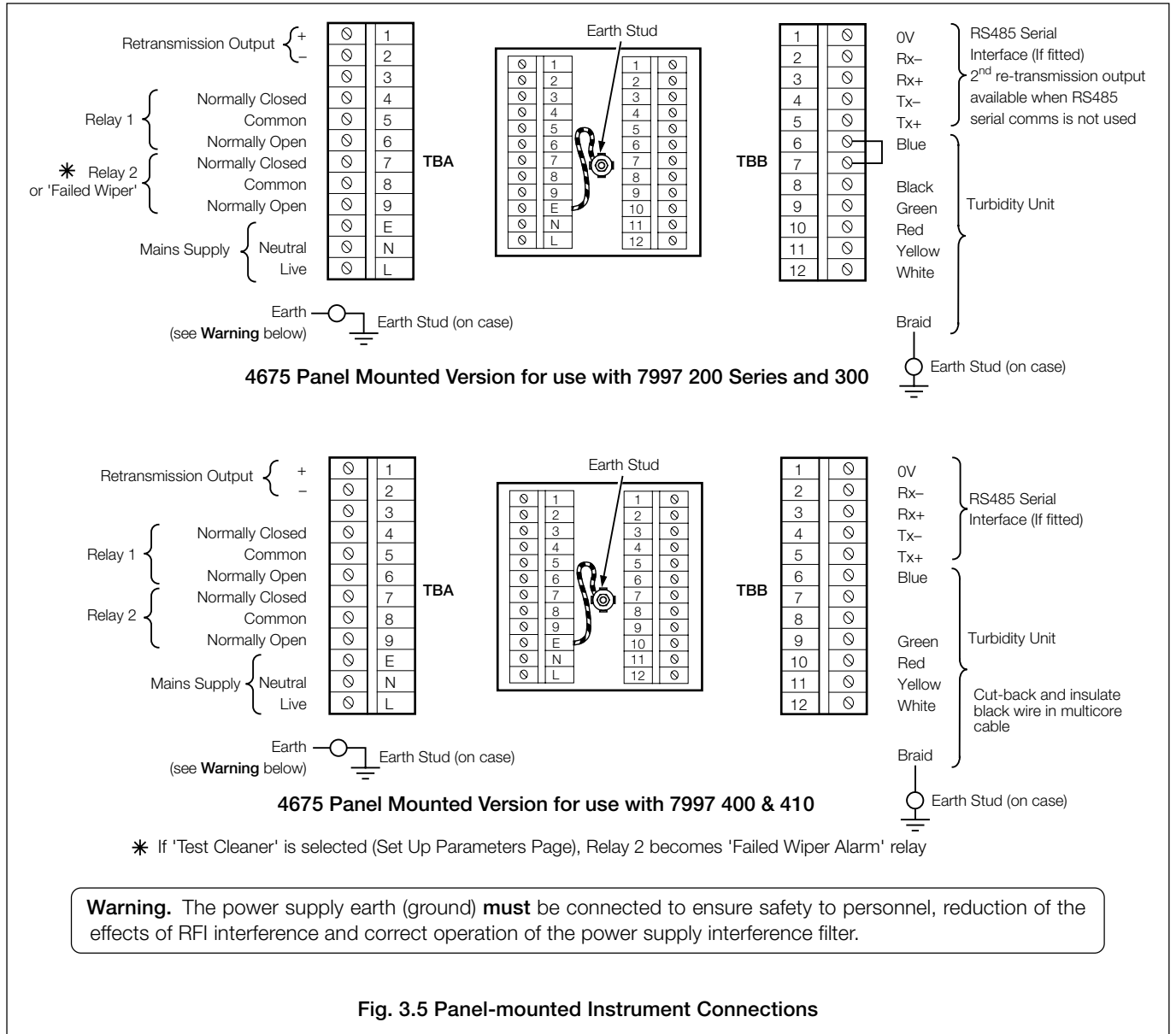

### 3.5 Selecting the Mains Voltage

#### 3.5.1 Wall-mounted Instrument

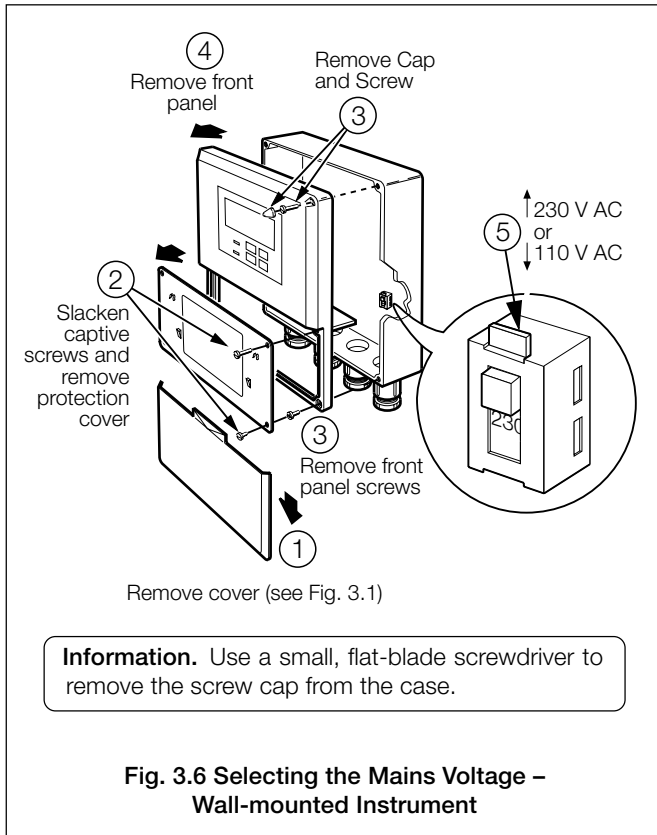

#### 3.5.2 Panel-mounted Instrument

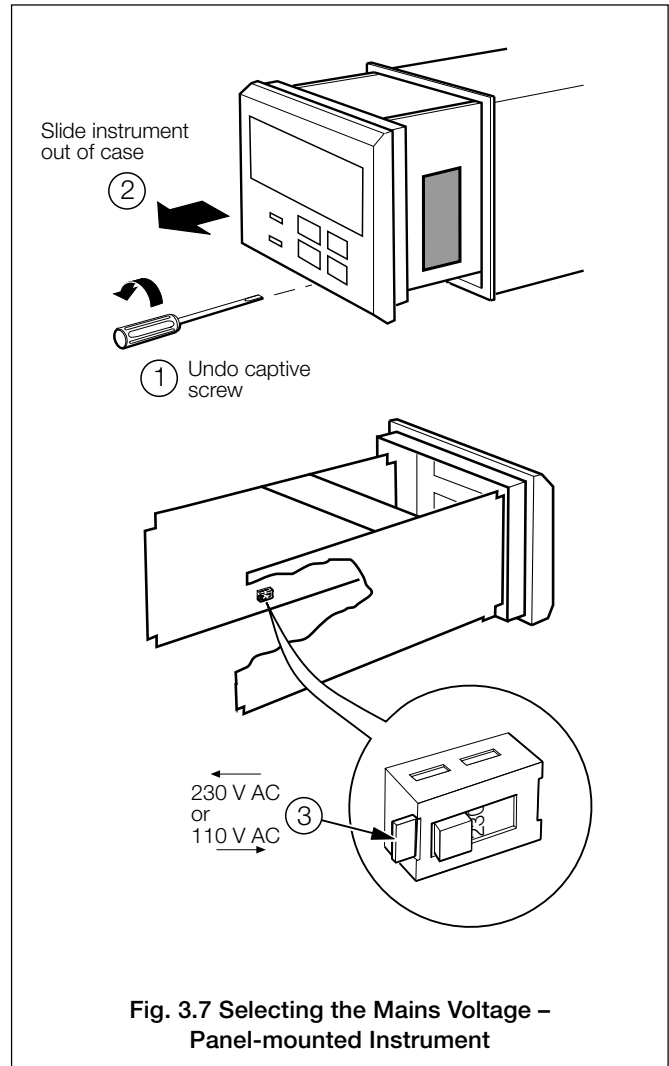

3.6 Turbidity Unit Connection Box – Fig. 3.8

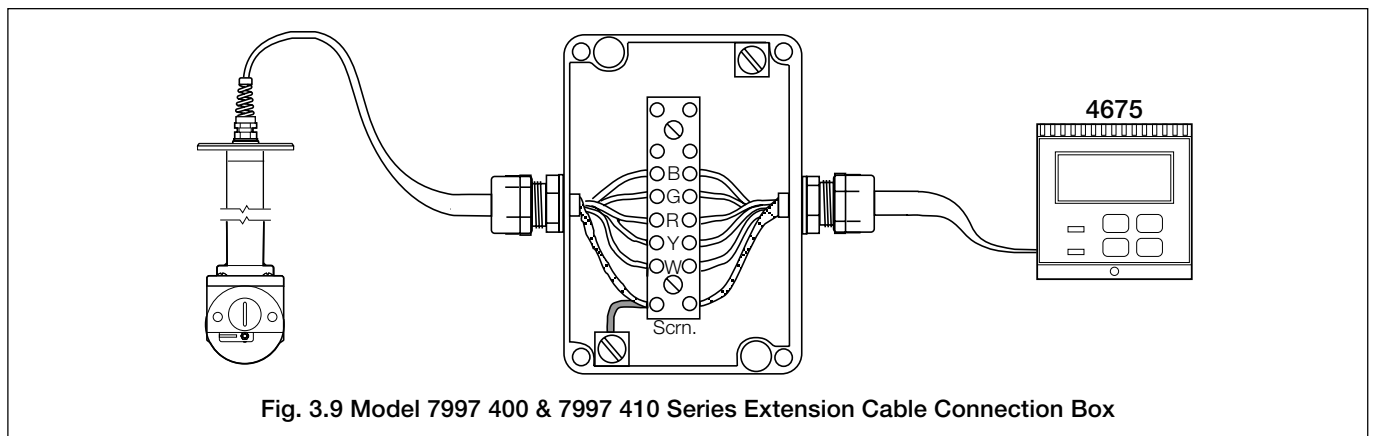
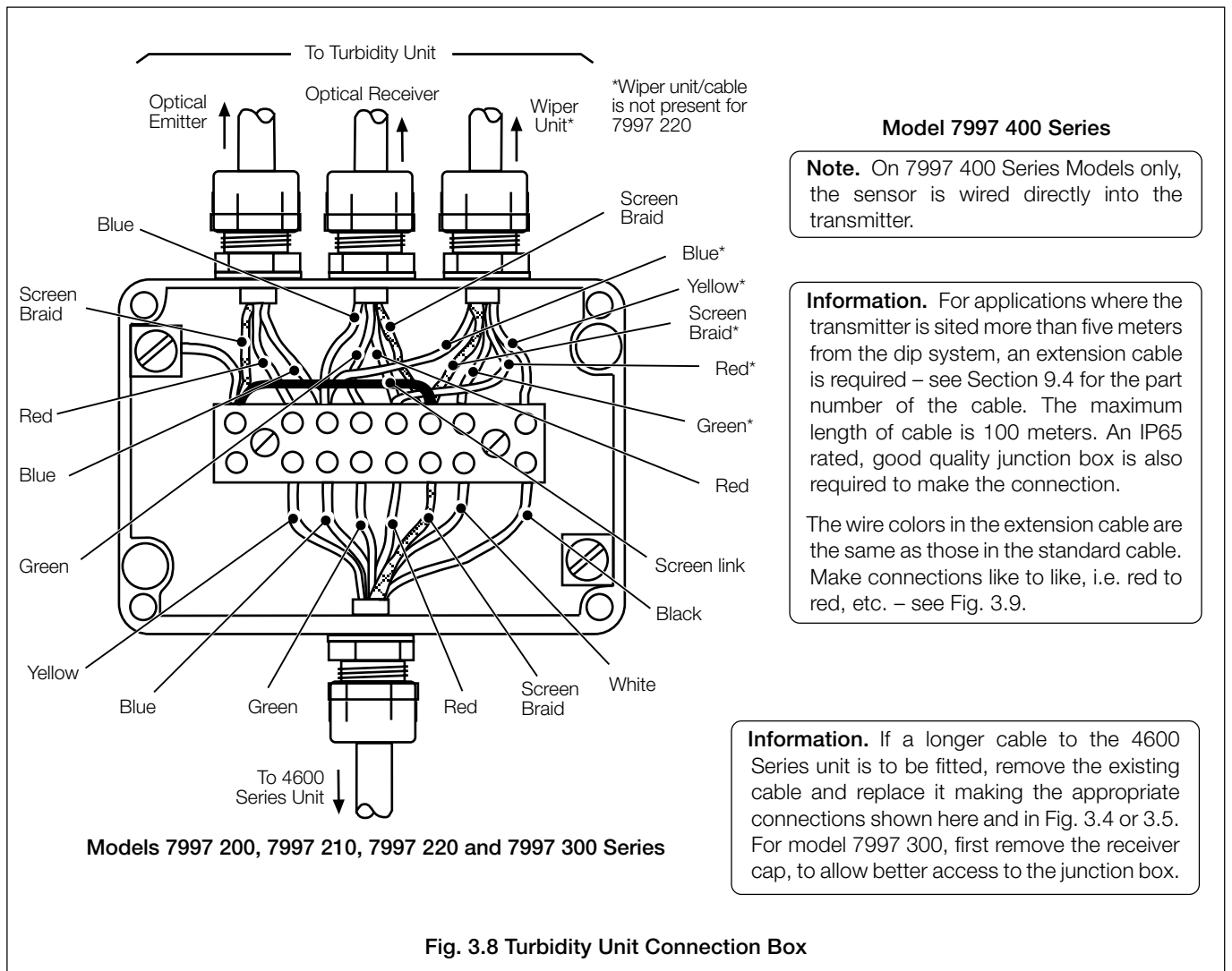

3.7 Connections for 7997 405

The 405 sensor comes with a 2m cable which connects in accordance with Fig 3.8, except that there is no Black wire.

## 4 CONTROLS AND DISPLAYS

### 4.1 Displays – Fig. 4.1

The display comprises a 5-digit, 7-segment digital upper display line and a 16-character dot-matrix lower display line. The upper display line shows actual values of turbidity, temperature, alarm set points or programmable parameters. The lower display line shows the associated units or programming information.

### 4.2 Control Familiarization

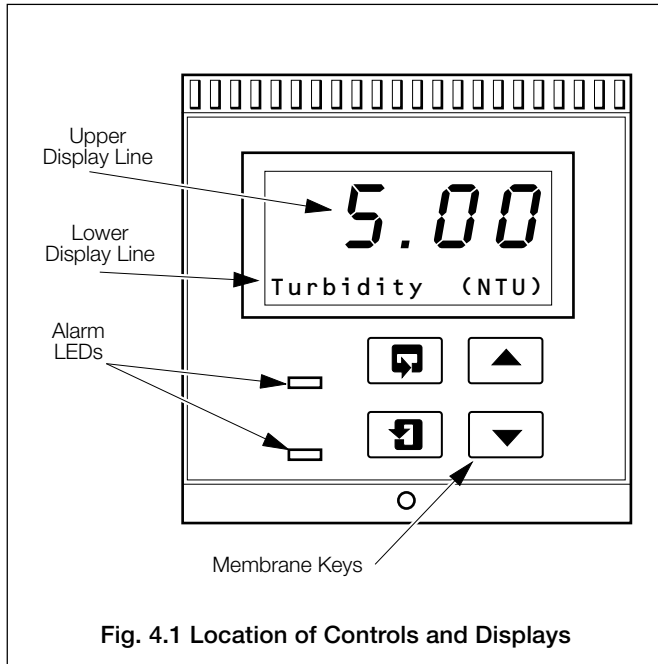
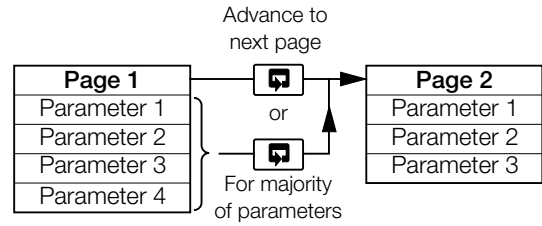
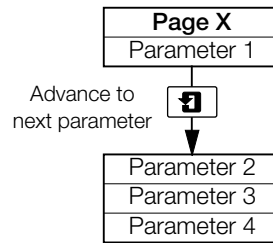

Fig. 4.1 Location of Controls and Displays



A – Advancing to Next Page



B – Moving Between Parameters

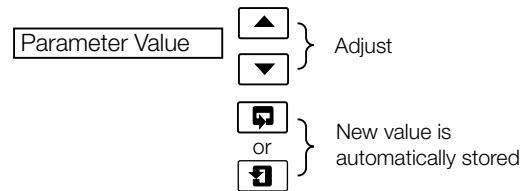

C – Adjusting and Storing a Parameter Value

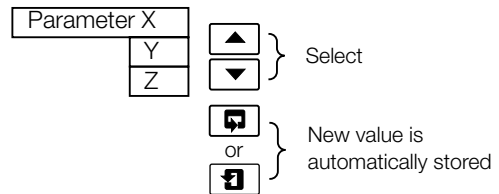

D – Selecting and Storing a Parameter Choice

Fig. 4.2 Membrane Key Functions

## 5 START UP AND OPERATION

### 5.1 Instrument Start-up

Ensure all electrical connections have been made and switch on the power supply. If the instrument is being commissioned for the first time, calibration (Section 7.4) and programming of parameters (Section 6) is required.

### 5.2 Operation – Turbidity Measurement Mode

Operation in the Turbidity measurement mode comprises an **Operating Page** and a **Turbidity Calibration Page**. The **Operating Page** is a general use page in which parameters are viewed only and cannot be altered. To alter or program a parameter, refer to the programming pages in Section 6. The **Turbidity Calibration Page** allows a calibration to be carried out. A 5-digit calibration code is used to prevent unauthorized access to the turbidity calibration page. The value is preset at 00000 to allow access during commissioning, but should be altered to a unique value, known only to authorized operators, in the **Set Up Outputs Page** – see Section 6.4.

#### 5.2.1 Operating Page

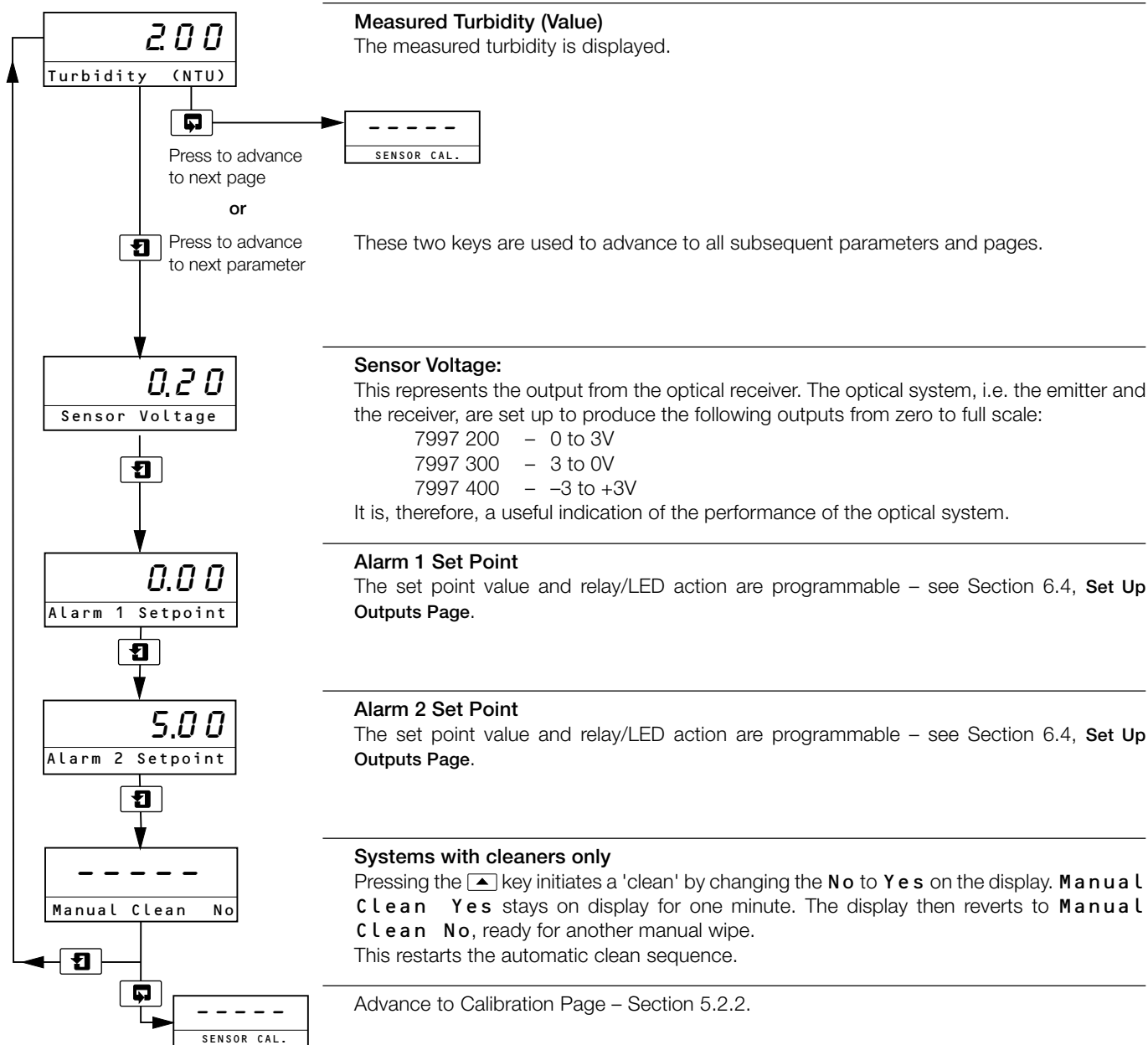

5.2.2 Calibration Page

Calibration involves standardizing the instrument using either a Dry Calibration Standard of a known turbidity value or by using a formazine standard solution, details of which are given in Section 7.

Example calibration sequences using the Dry Standard and a Formazine Standard, follow. Specific details of calibration procedures for all models are also given in Section 7.

For calibration in suspended solids mode, refer to Appendix B1.2.

Dry Standard Calibration – see also Section 7.1.3

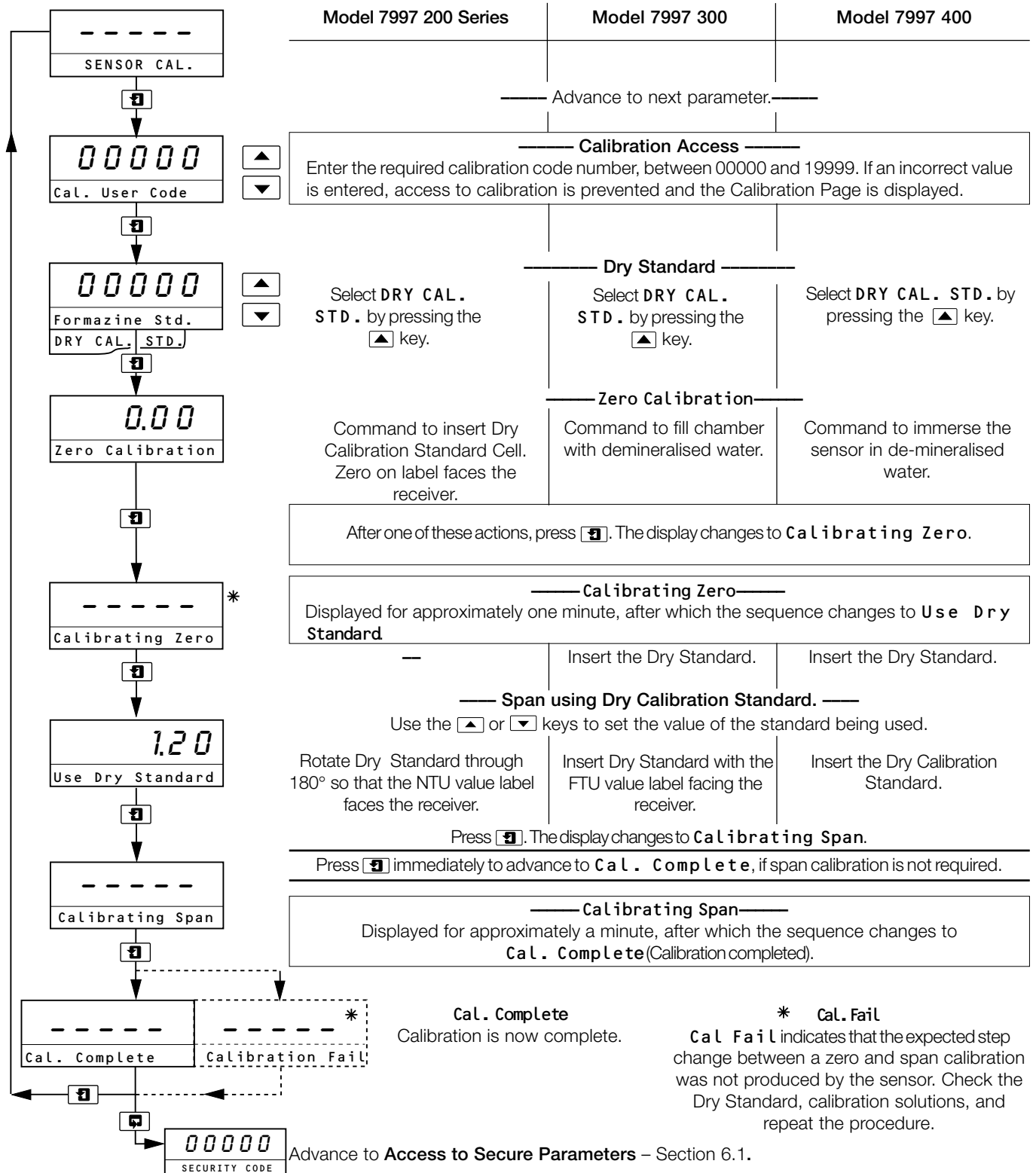

...5.2.2 Calibration Page

Formazine Standard (wet) Calibration – see also Section 7.3.1.

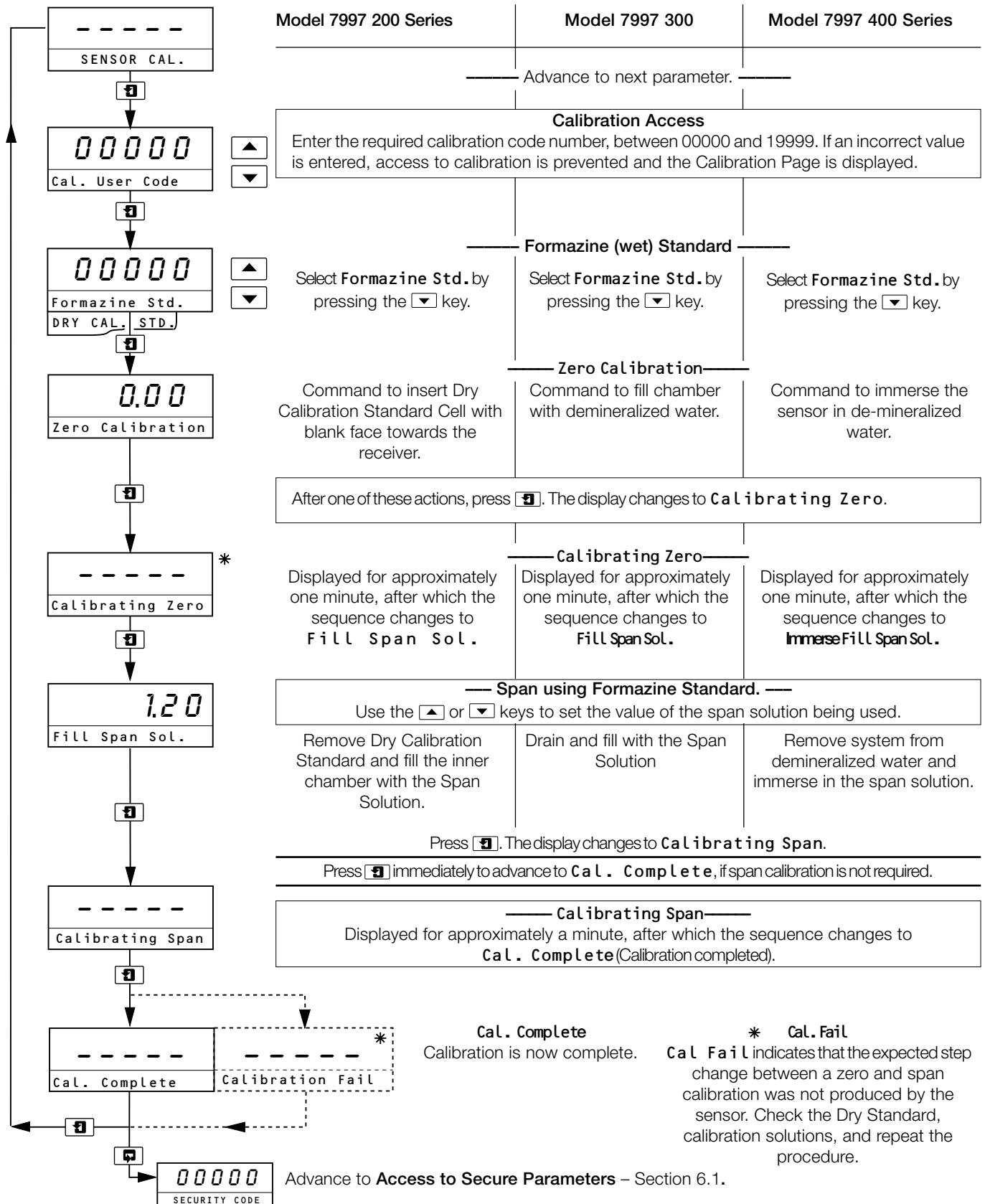

# 6 PROGRAMMING & ELECTRICAL CALIBRATION

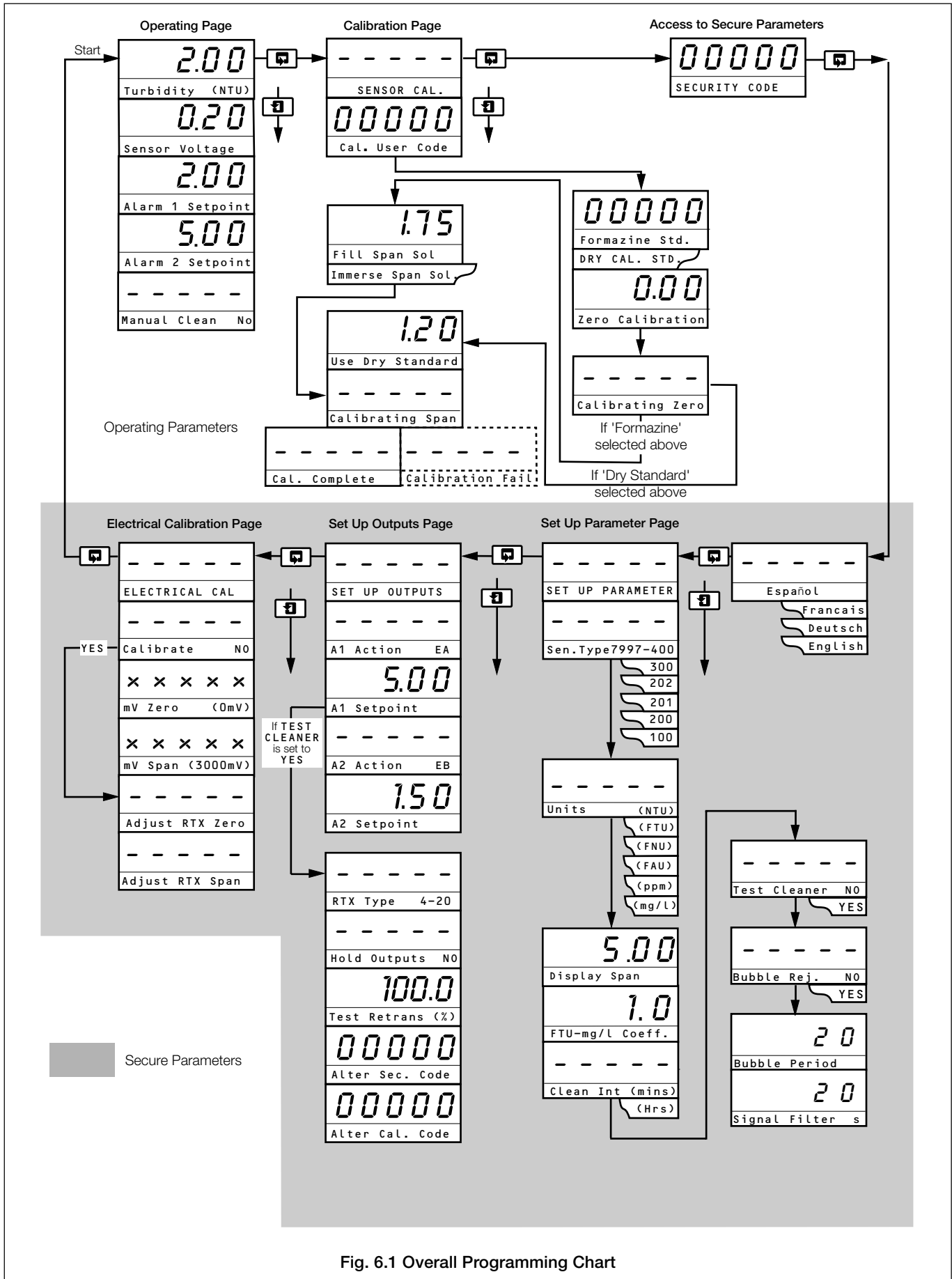

Fig. 6.1 Overall Programming Chart



**6.1 Access to Secure Parameters**

A 5-digit security code is used to prevent unauthorized access to the secure parameters.



**Security Code**

Enter the required code number, between 00000 and 19999, to gain access to the secure parameters. If an incorrect value is entered, access to subsequent programming pages is prevented and the **Operating Page** is displayed.

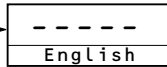

Advance to **Language Page**.

**6.2 Language Page**

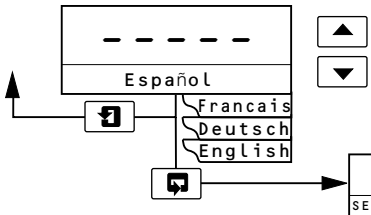

**Language**

Use the and keys to select the required language.



Advance to **Set Up Parameter Page**.

**6.3 Set Up Parameter Page**

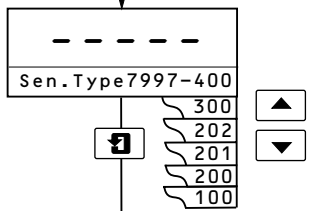
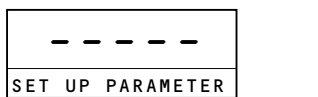

**Sensor Type**

Select the required sensor:

- 7997 100 (No longer available. ( replaced with 7997 201 and 202)
- 7997 200
- 7997 201
- 7997 202
- 7997 300 or
- 7997 400

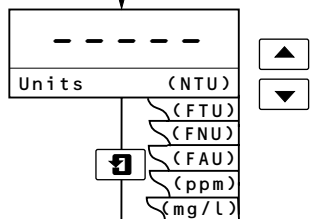

**Turbidity Units (7997 200 Series, 7997 300, 7997 400 Series)**

- NTU** – Nephelometry Units (7997 200 Series).
  - FNU** – Formazine Nephelometry Units (7997 200 Series).
  - FTU** – Formazine Turbidity Units (7997 300 and 7997 400 Series).
  - FAU** – Formazine Attenuation Units (7997 300 and 7997 400 Series).
  - ppm** – Suspended solids (7997 200 Series, 7997 300 and 7997 400 Series).
  - mg / L** – Suspended solids (7997 200 Series, 7997 300 and 7997 400 Series).
- Select the required turbidity units.

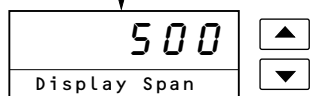

**Display Span**

Select the required span value. The display flashes at turbidity values higher than the selected span value, but will indicate correctly up to the range of the sensor – see Section 8. The Display Span also sets the correct output span, and alarm values cannot be set outside this range.

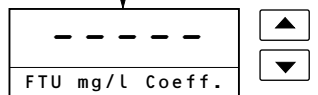

**Correction Factor** – available only if the units **mg / L** or **ppm** are selected (see Appendix B for suggested method for determining the correction factor)

Select the required correction factor as determined by the method given in Appendix B – programmable between 02. to 5.0.

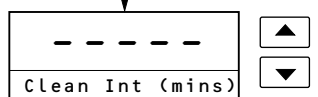

**Cleaning Interval (Not 7997 202)**

Select the cleaning interval required. Values available are: 15 min, 30 min, 45 min, 1 h, then 1 h increments to a maximum of 24 hours.

Continued on next page.

...6.3 Set Up Parameter Page

continued from previous page

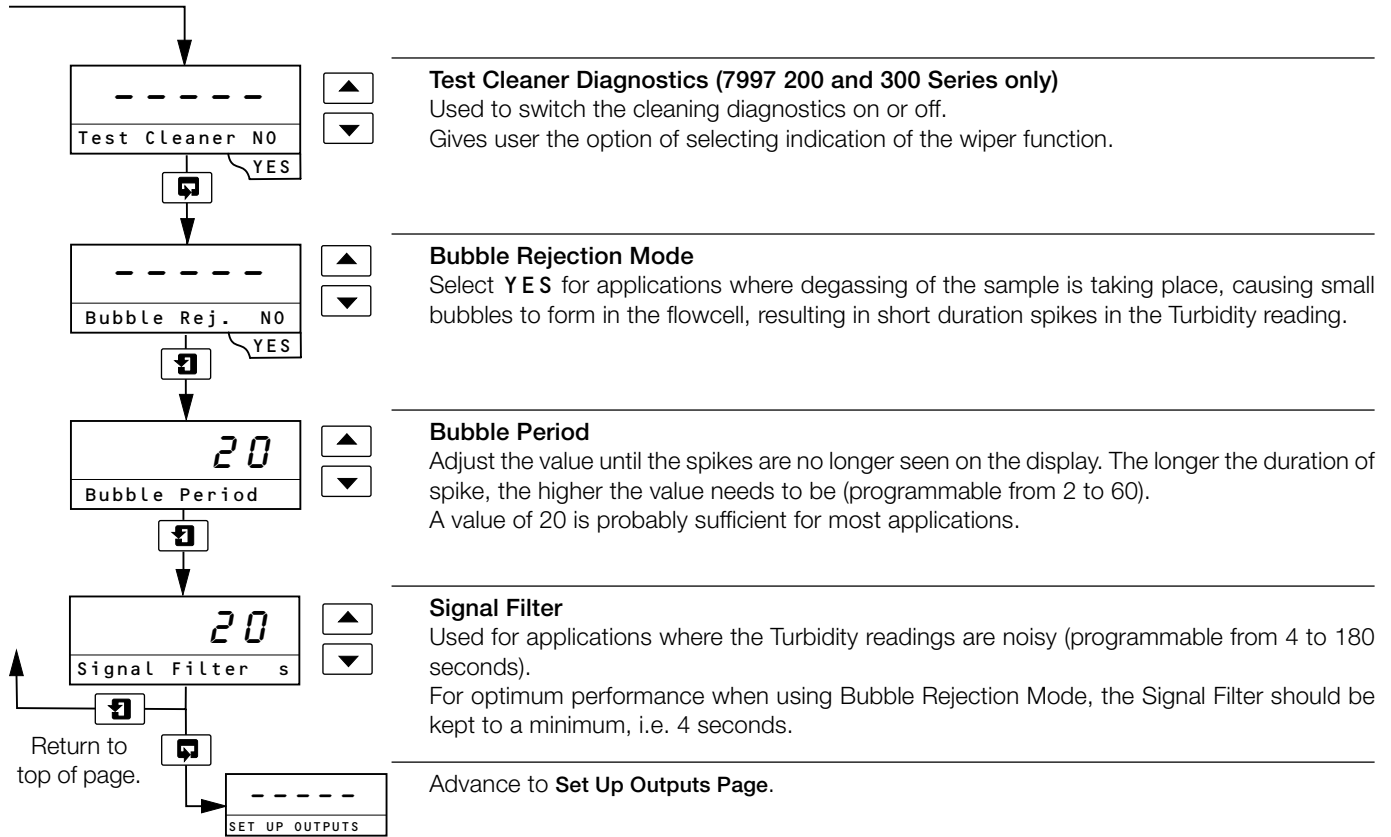

6.4 Set Up Outputs Page

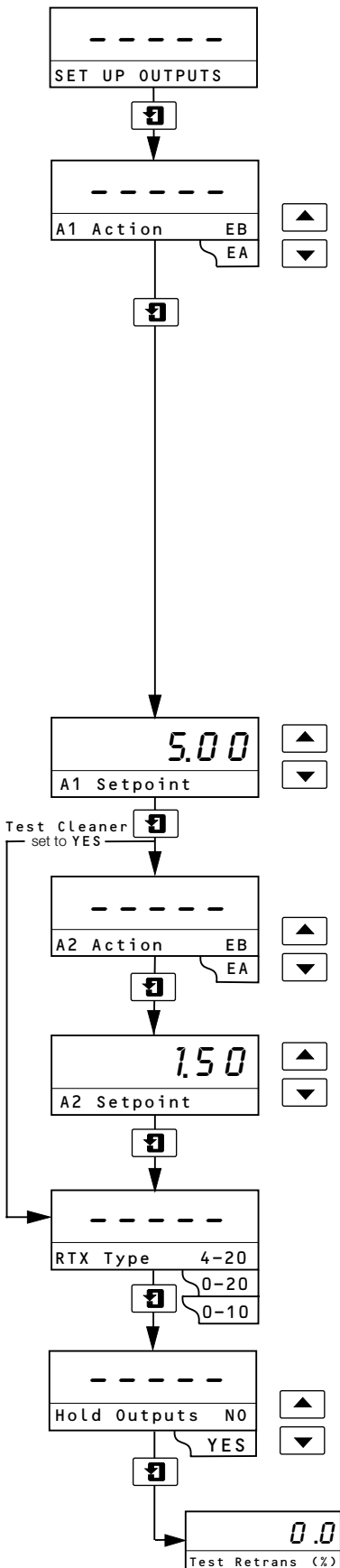

**Alarm 1 Action**

For 'Fail-safe' alarm operation the relay's alarm state must be the same as the power-down state, i.e. the relay is de-energized.

For high alarm operation the relay must be **Energized Below** the alarm set point (EB). For low alarm operation the relay must be **Energized Above** the alarm set point (EA). The alarm LEDs are illuminated in the alarm condition.

Select the required alarm 1 action from the following table:

Alarm Action	LED Action for input Above Set Point	LED Action for input Below Set Point	Relay Action for input Above Set Point	Relay Action for input Below Set Point
EB	ON	OFF	De-energized	Energized
EA	OFF	ON	Energized	De-energized

The set point band is defined as the actual value of the set point plus or minus the hysteresis value. The hysteresis value is  $\pm 1\%$  of the set points displayed in the **Set Up Parameter Page** – see Section 6.3. Alarm action occurs if the input value is above or below the set point band. If the input moves within the set point band the last alarm action is maintained.

**Alarm 1 Set Point**

The alarm 1 set point can be set to any value within the display span selected. The set point value is subject to hysteresis as detailed above.

Set the alarm set point to the required value.

**Alarm 2 Action**

Repeat as for Alarm 1 Action above.

Becomes **Failed Wiper Alarm** if **Test Cleaner** is set to **YES** in the **Set Up Parameter Page**.

**Alarm 2 Set Point**

Repeat as for Alarm 1 Set Point above.

**Retransmission Output Assignment**

Select mA current output, from 0 to 10, 0 to 20 or 4 to 20 mA, using the  and  keys.

The current output range is assigned to the display span selected.

**Hold Outputs during Calibration**

The retransmission and alarm outputs can be held to prevent inadvertent operation during a calibration procedure.

Select either **YES** or **NO**.

Continued on next page.

...6.4 Set Up Outputs Page

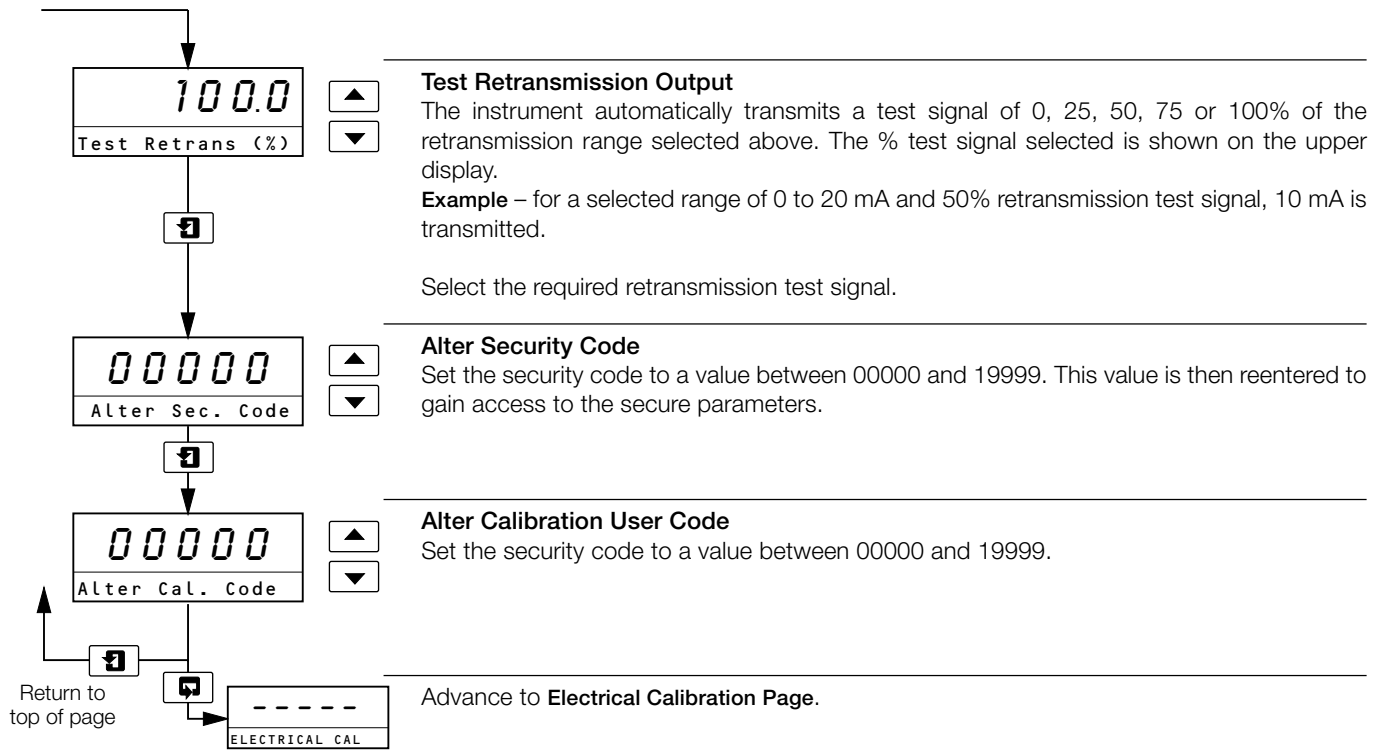

## 6.5 Electrical Calibration

**Caution.** The instrument is calibrated by the company prior to despatch and an electrical calibration should not be necessary. If an electrical calibration is carried out, suitably calibrated and verifiable test equipment must be used.

### 6.5.1 Equipment Required

- a) Millivolt source 0 to +4000 mV.
- b) Digital milliammeter (current output measurement): 0 to 20 mA.

## 6.6 Preparation

- a) Switch off the supply and disconnect the turbidity cell and current output from the electronics unit terminal block – see Fig. 3.4 or Fig. 3.5.
  - b) **Wall Mounted Instruments**
    - 1) Connect the millivolt source '+' and '-' to terminals 4 and 7 respectively.
    - 2) Connect the milliammeter to the retransmission output terminals.
    - 3) Ensure the earth on the millivolt source is connected to the earth stud.
- Panel Mounted Instruments**
- 1) Connect the millivolt source '+' and '-' to terminals 9 and 6 respectively.
  - 2) Connect the milliammeter to the retransmission output terminals.
  - 3) Ensure the earth on the millivolt source is connected to the earth stud.
- c) Switch on the supply and allow ten minutes for the circuits to stabilize.
  - d) Select **ELECTRICAL CAL Page** and proceed as in Section 6.7, following.

6.7 Electrical Calibration Page

In this section the actual values denoted by 'xxxxx' are unimportant and are used to determine display reading stability when carrying out the electrical calibration procedure.

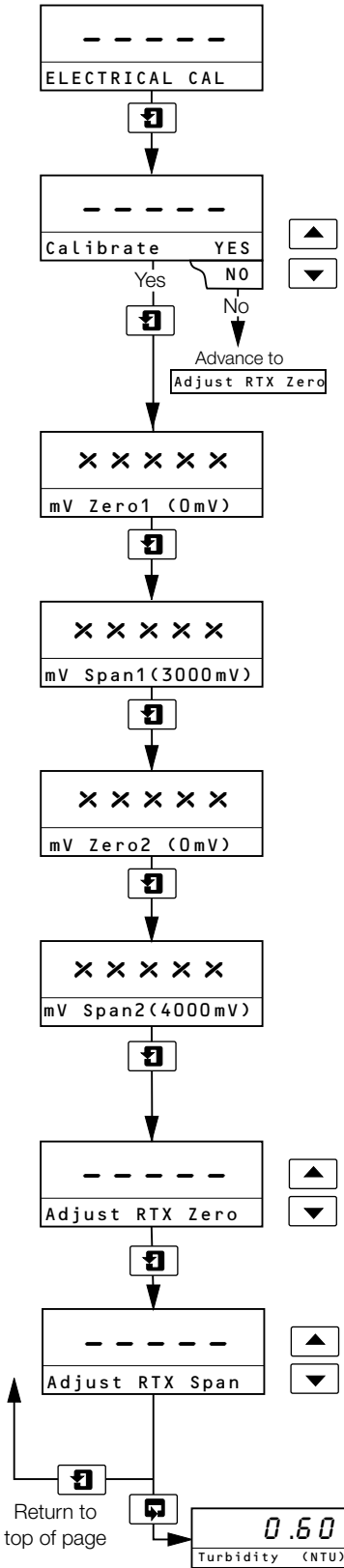

**Electrical Calibration**

Select **YES** to access the electrical calibration sequence. Select **NO** to advance to **Adjust RTX Zero**.

**Millivolt Zero (7997 200 Series, 7997 300)**

Set the millivolt source to 0 mV and allow the instrument display to stabilize.

**Millivolt Span (7997 200 Series, 7997 300)**

Set the millivolt source to +3000 mV and allow the instrument display to stabilize.

**Millivolt Zero (7997 400 Series)**

Set the millivolt source to 0 mV and allow the instrument display to stabilize.

**Millivolt Span (7997 400 Series)**

Set the millivolt source to +4000 mV and allow the instrument display to stabilize.

**Note.** Retransmission adjustment is achieved using 4 to 20 mA. The correct values for 0 to 20 and 0 to 10 mA will then be derived automatically.

**Adjust Retransmission Zero**

Set the milliammeter reading to 4 mA.

**Adjust Retransmission Span**

Set the milliammeter reading to 20 mA.

**Note.** The retransmission range selected in the **Set Up Outputs Page** does not affect the reading.

Return to the **Operating Page**.

---

## 7 MAINTENANCE

---

### 7.1 Scheduled Maintenance

The following servicing schedule has been produced as a general guide only. Because the systems are designed for a wide range of applications, where the nature of the sample can vary considerably, it may be necessary to amend the schedule to suit the particular installation and sample conditions.

#### 7.1.1 Sensor Cleaning Model 7997 202

The Model 7997 202 sensor unit is generally used on clean water samples and maintenance should be limited mainly to manual monthly cleaning of the flow chamber, under normal conditions. If there is a high turbidity breakthrough, clean the chamber immediately to ensure accurate readings.

#### Models 7997 200 Series, 300 and 400 Series

The required automatic cleaning frequency of the flow chamber and optical windows of Models 7997 200 Series, 300 and 400 Series can only be determined by plant experience. It is recommended that checks are made at appropriate intervals.

#### 7.1.2 Calibration

A key feature of the system is the optional Dry Calibration Standard, which simplifies routine calibration and virtually eliminates the need for formazine standard solutions to be produced.

These dry standards are safer, ensure repeatable accurate results and eliminate operator error. However, the software is designed to cater for both methods if the use of formazine standards are preferred.

### 7.1.3 Using Dry Calibration Standards

Dry Calibration Standards are used to verify system accuracy. They provide a means of verifying the integrity of the loop without the need for chemical standard solutions.

#### Note.

- The Dry Calibration Standard for the 7997 300 and 400 are specific to the sensor unit with which they are supplied.
- Always store the Dry Calibration Standard in the container provided, and keep in a dry place.
- Avoid touching the light reflecting parts of the standard.

Each Dry Calibration Standard is verified against a formazine standard before delivery, and the turbidity value is indicated on the label.

## 7.2 Calibration Checks

The system uses LED technology and very stable electronics which avoids the risk of electronic drift. Therefore, routine calibration is normally unnecessary. However, it may be necessary to routinely check the system accuracy (particularly after cleaning). This should then be considered as a calibration check and not a calibration adjustment.

### 7.2.1 Procedure

#### Model 7997 200 Series

- Shut off sample water using the isolating valve installed upstream of the sensing unit.
- Drain the unit by closing the inlet and opening the drain valve. Carefully remove the wiper unit to aid complete drainage of the system. When the system is empty, close the outlet valve.
- Thoroughly dry the inner chamber using clean tissue and wipe clean the emitter and receiver lenses. Ensure that no greasy marks are left on the lenses and that the lenses are dry.

**Note.** If the sample was cold, condensation could form on the windows. It may be necessary, therefore, to leave the sensor open for a short while to allow the windows to reach ambient temperature before attempting calibration.

**Note.** The dry calibration procedure for the 7997 300 and 7997 400 requires the use of demineralized water for zero calibration.

- Insert the Dry Calibration Standard with the zero on the label facing the receiver.

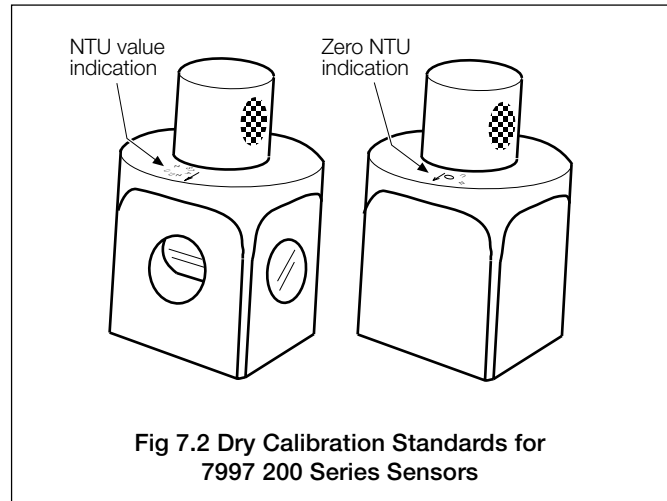

- Rotate the Dry Calibration Standard so that the turbidity value on the label is facing the receiver. Note the reading on the display. If readings are out of spec. ( $\pm 2\%$  FSD), repeat the procedure from c). If reading is still out of spec., calibrate the sensor – Section 5.2.2.
- Take out the Dry Calibration Standard; dry/clean off any moisture before storing the Standard in the supplied storage container – see also Section 7.4.1 – Care and Maintenance of Dry Calibration Standards.
- Fit the Sensor Unit top cap (7997 202) and screw it down firmly, or fit the wiper unit (7997 200 and 201).
- Open the inlet valve. Ensure that the flow through the sensor is  $0.5$  to  $6.0 \text{ l min}^{-1}$

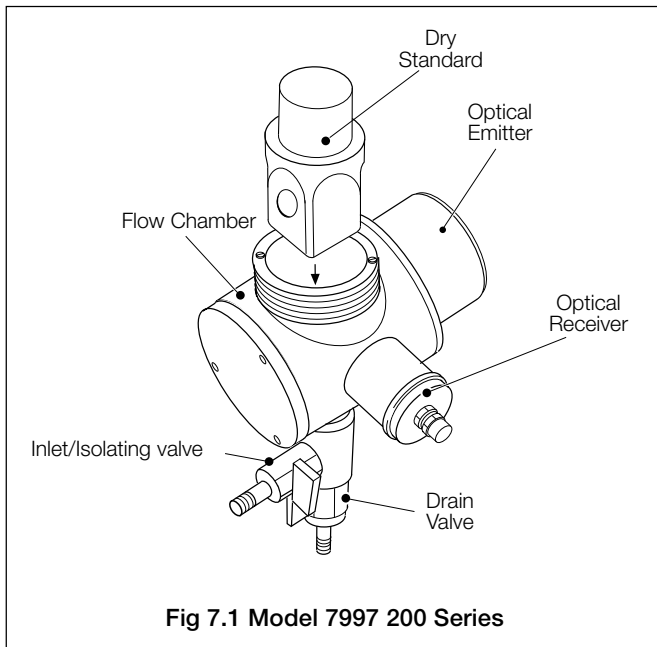



## ...7.2.1 Procedure

**Model 7997 300**

- Shut off sample water using the isolating valve installed upstream of the sensing unit.
- Drain the unit by closing the inlet and opening the drain valve. Carefully unscrew and remove the wiper unit to aid complete drainage of the system. When the system is empty, close the outlet valve.
- Thoroughly dry the inner chamber using clean tissue and wipe clean the emitter and receiver lenses. Ensure that no greasy marks are left on the lenses and that the lenses are dry.
- Close the drain valve and fill the chamber with high purity water. Note the reading on the display. If readings are out of spec. ( $\pm 2\%$  FSD), repeat the procedure from c). If reading is still out of spec., calibrate the sensor – Section 5.2.2.
- Insert the Dry Calibration Standard so that the turbidity value on the label is facing the emitter. Note the reading on the display.

**Note.** If the sample was cold, condensation could form on the windows. It may be necessary, therefore, to leave the sensor open for a short while to allow the windows to reach ambient temperature before attempting calibration.

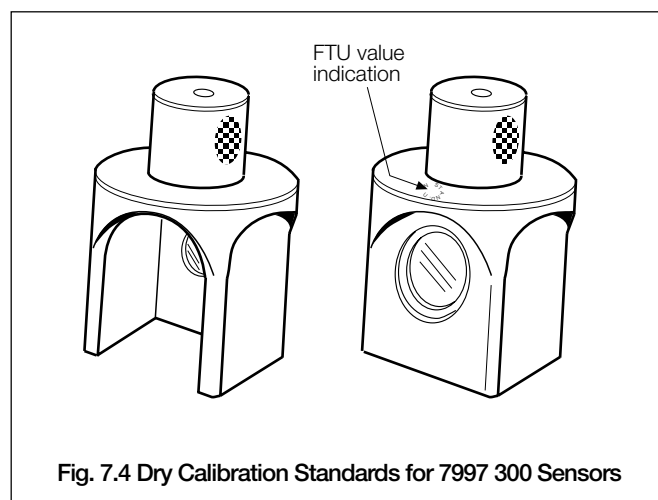
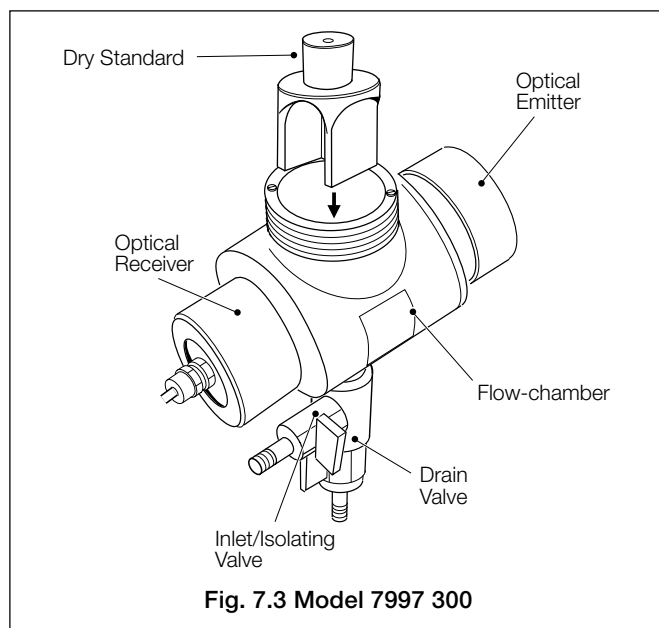

- Take out the Dry Calibration Standard; dry/clean off any moisture before storing the Standard in the supplied storage container – see also Section 7.4.1 – Care and Maintenance of Dry Calibration Standards.
- Fit the wiper Unit and screw it down firmly.
- Open the inlet and outlet valves. Set the sample rate to  $0.5$  to  $6.0 \text{ l min}^{-1}$

...7.2.1 Procedure

Model 7997 400 Series

**Caution.** Before removing the sensor from the sample, ensure the programmed cleaning interval (**Set Up Parameters Page**), is greater than the estimated maintenance time and then set **'Manual Clean'** (**Operating Page**) to **'YES'**. This ensures that the cleaning interval restarts to give the full cycle time.

Under normal circumstances, when the sensor is exposed to air any programmed or manual wiping is automatically suspended until the probe is immersed again. The above instructions provide further safety to minimize the possibility of the wiper causing injury during calibration procedures.

- a) Remove dip system by releasing it from the fixing bracket.
- b) Thoroughly clean the system using high purity water to remove any contamination, and dry carefully using a soft cloth.
- c) Immerse the dip system into a container of high purity water. Note the reading on the display.
- d) After removing the dip system from the high purity water, dry the unit using clean tissue. Wipe clean the emitter and receiver lenses making sure that no greasy marks are left on the lenses.
- e) Lie the unit on a horizontal surface and insert the Dry Calibration Standard – see Fig. 7.1. Ensure that the sensor standoff pillar is fully engaged in the slot in the Dry Calibration Standard. Note the reading on the display. If readings are out of spec. ( $\pm 2\%$  FSD), repeat the procedure from b). If reading is still out of spec., calibrate the sensor – Section 5.2.2.

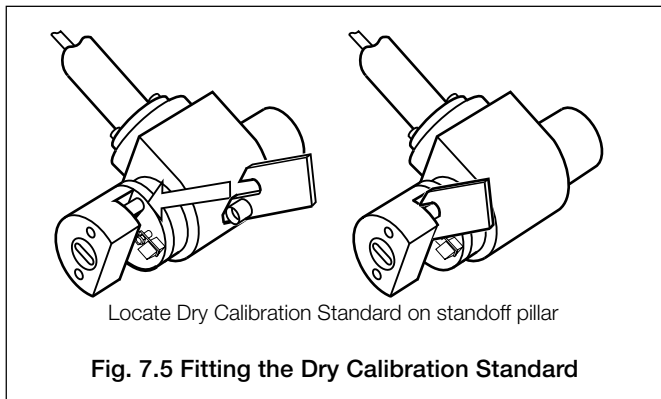

- f) Remove the Dry Calibration Standard; dry clean off any moisture before storing the Standard in the supplied storage container.
- g) Fit the unit into the working position and secure.

7.3 Using Formazine Standard Solution

7.3.1 Preparing the Formazine Standard for Wet Calibration

- a) Dissolve 50.0 g of hexamethylenetetramine ( $C_6H_{12}N_4$ ) in high purity water and dilute to 400 ml – **Solution A**.

**Warning.** Hydrazine sulfate is poisonous and carcinogenic.

- b) Dissolve 5.0 g of hydrazine sulfate ( $N_2H_6SO_4$ ) in high purity water and dilute to 400 ml – **Solution B**.
- c) Mix solution A with solution B; shake well and leave in the dark for 24 hours at  $25^\circ C \pm 3^\circ C$ .
- d) Dilute the solution to one liter with high purity water.

The turbidity of this stock solution in formazine attenuation units (FAU) or formazine nephelometric units (FNU) is 4000.

The solution is stable for 1 year if stored at  $25^\circ C \pm 3^\circ C$  in the dark.

**If it is necessary to conform to the British European Standard BS.EN.27027 for preparation of formazine standards:**

- e) Dissolve 10.0 g of hexamethylenetetramine ( $C_6H_{12}N_4$ ) in high purity water and dilute to 100 ml – **Solution A**.
- f) Dissolve 1.0 g of hydrazine sulphate ( $N_2H_6SO_4$ ) in high purity water and dilute to 100ml – **Solution B**.
- g) Mix 5 ml of solution A with 5 ml of solution B; shake well and leave in the dark for 24 hours at  $25^\circ C \pm 3^\circ C$ .
- h) Dilute the solution to 100 ml with high purity water.

The Turbidity of this stock solution in formazine attenuation units (FAU) or formazine nephelometric units (FNU) is 400.

The solution is stable for one month if stored at  $25^\circ C \pm 3^\circ C$  in the dark.

- i) Dilute the stock solutions with high purity water using pipettes and volumetric flasks to obtain the required diluted standards in the range required.

**Note.** These solutions are stable for one week only. Dispose after use in accordance with relevant local safety standards.

## 7.4 Unscheduled Maintenance

If the instrument fails to produce results as expected, the following checks should be made for the messages displayed. The majority of problems are overcome by thorough cleaning of the optical windows in the flowcell and or a sensor calibration.

### 7.4.1 Transmitter Diagnostic messages

#### Cal Fail (7997 200 and 300 Series only)

Indicates that the expected step change between a zero and span calibration was not produced by the sensor, i.e. zero response from the sensor.

- a) Repeat calibration.
- b) If using a dry calibration standard, ensure that the optical windows on the dry standard are clean and dry.
- c) If using solutions, check that the flowcell has been thoroughly cleaned, and rinse well between solutions.
- d) If using solutions, check both zero and formazine solutions.
- e) Check electrical connections to sensor.
- f) Check the sensor 12V supplies, using a suitable voltmeter, both at the transmitter terminals and sensor junction box – see Table 3.1 for connection details.
- g) Check transmitter response to an electrical input by injecting 0 and 3V into the following terminals and noting the voltage on the Sensor Voltage display in the software:

Wall mounting	–ve to terminal 7	+ve to terminal 4
Panel mounting	–ve to terminal 6	+ve to terminal 9

Small errors in displayed voltage can be removed by electrical calibration. Large errors would indicate an electronic fault.

#### Cleaner Fail (7997 200 and 300 Series only)

Indicates that the transmitter was unable to detect the correct operation of the cleaner; either the cleaner did not rotate or failed to park in the correct position.

- a) Check the electrical connections to the sensor.
- b) Check the sensor 12V supplies, using a suitable voltmeter, both at the transmitter terminals and sensor junction box – see Table 3.1 for connection details.
- c) Check operation of the cleaner unit by disconnecting the white lead from the transmitter terminal block (Cleaner Initiate signal). Touch and release the white lead to the 0V terminal – see Table 3.1 for connection details. This initiates a cleaning cycle, which can be observed when the cleaner is removed from the flowcell.

#### NV Memory Error

Indicates that the contents of the nonvolatile memory has not been read correctly during power up. To rectify the problem, switch off the power, wait 10 seconds, and switch on again. If the problem persists contact the Company.

### 7.4.2 Unstable or Erratic Readings

This is usually caused by air bubbles in the sample and is usually more pronounced on the low level 7997 200 Series sensors due to their greater sensitivity. These bubbles are usually as a result of degassing of the sample, caused by a drop in sample pressure, or a rise in temperature. Frequent cleaning of the optical windows will help to prevent bubbles building up on the windows. It is recommended that the De-bubbler unit is installed – see Section 2.3.6. If the problem persists refer to Section 7.4.3

Where the noise level gradually gets worse over a period of time, this usually indicates that solids are building up in the flowcell. Increasing the flowrate through the flowcell, may reduce this build up. Ultimately the flowcell needs to be cleaned manually.

### 7.4.3 Intermittent Short Term Spikes in Turbidity Readings

This is usually due to bubbles going through the light path within the flowcell. These bubbles are as a result of degassing. Degassing is not an instantaneous process and it is possible that it is taking place after the sample has gone through the de-bubbler. The bubbles start to form in the sample pipework and the flowcell. As they grow gradually, the bubbles finally release and flow through the light path, causing a spike in the turbidity reading.

The transmitter can be programmed for Bubble Rejection, which removes these short term spikes from the readings. – see Section 6.3. For optimum operation the Cleaner should be operated as frequently as possible to prevent bubbles building up on the windows.

### 7.4.4 Care and Maintenance of Dry Calibration Standards

- Ensure that any residual moisture has been carefully wiped off after use. It is essential that the Dry Calibration Standard is always stored in the container provided when not in use.
- Avoid direct contact with the glass prism. Fingerprints on the device could alter its stated value.
- Clean the prism with a cotton, lint-free cloth.
- The storage container includes a silica gel dryer. Replace this dryer annually.
- Return the Dry Calibration Standard to The Company annually for checking.

**Important Note.** When returning the Dry Calibration Standard for checking, ensure that it is packed in the original storage container.

### 7.4.5 Determination of the Dry Standard Value for the 7997 300 and 400 Series Sensors

The dry standards supplied with the 7997 300 and 7997 400 series of systems are instrument specific. Therefore, if a replacement dry standard is purchased, or if one has been purchased subsequent to delivery of the system, then the value of the standard has to be determined when used with the specific system.

- a) Follow the instructions in Section 5.2.2 for formazine calibration.
- b) Dry the sensor with care.
- c) Insert the new dry standard and take note of the reading obtained. This reading will be the value of the dry standard.
- d) Mark the dry standard with this value.

### 7.4.6 Converting 7997 202 Sensor to 7997 201 Sensor (with Integral Cleaning)

It may be necessary to upgrade from a wiperless 7997 202 sensor to a 7997 201 sensor with wiper. To upgrade the sensor 7997 202 proceed as follows:

- a) Shut off sample water using the isolating valve installed upstream of the sensor unit.
- b) Drain the unit by closing the inlet and opening the drain valve. Carefully remove the sensor unit top cap to aid complete drainage. When the system is empty, close the drain valve.
- c) Fit the new wiper unit and use the collar previously used to secure the top cap. Wire the wiper cable into the turbidity unit connection box – see Fig. 3.8 for connection details.
- d) Change sensor type from 7997 202 to 7997 201 and set clean interval – see Section 6.3 Set Up Parameter Page.

**Note.** A calibration should be carried out before operating the turbidity sensor.

- e) Follow the Calibration procedure in Section 5.2.2.

## 8 SPECIFICATION

### Specification

#### 7997-200 Turbidity Sensor

##### Range

Programmable 0 — 25 NTU to 0 — 250 NTU and  
0 — 500mg/l (or p.p.m.) \*

##### Measurement Principle

90° scattered light measurement. Compliant to ISO7027

##### Measurement Characteristic

Linear based on Formazine

##### Resolution

0.1 NTU

##### Repeatability

Better than 1% of span

##### Accuracy

±2% of reading (limited by uncertainty in Formazine standards)  
from  
0 to 100 NTU  
±5% from 100 to 250 NTU

##### Temperature drift

0.005 NTU/10°C (0.003 NTU/10°F)

##### Response time

Varies with flow rate, typically 90% step change in  
2 minutes at 1 l/min.

##### Flow rate

0.5 l to 1.5 l/min

##### Integral wiper cleaning system

Programmable operational frequency every 0.25 hour, 0.5 hour,  
0.75 hour or multiples of 1 hour up to 24 hours

##### Sample operating temperature

0 to 50°C (32 to 122°F)

##### Sample Pressure

Up to 3 bar (43.5 psi)

#### 7997-201 & 7997-202 Turbidity Sensors

##### Range

Programmable 0 — 1 NTU to 0 — 30 NTU

##### Measurement Principle

90° scattered light measurement. Compliant to ISO7027

##### Measurement Characteristic

Linear based on Formazine

##### Resolution

0.01 NTU

##### Repeatability

Better than 1% of span

##### Accuracy

±2% of reading (limited by uncertainty in Formazine standards)

##### Temperature drift

0.005 NTU/10°C (0.003 NTU/10°F)

##### Response time

Varies with flow rate, typically 90% step change in less than  
45s at 1 l/min

##### Flow rate

0.5 l to 1.5 l/min

##### Integral wiper cleaning system (7997-201 only)

Programmable operational frequency every 0.25 hour, 0.5 hour,  
0.75 hour or in multiples of 1 hour up to 24 hours

##### Sample operating temperature

0 to 50°C (32 to 122°F)

##### Sample pressure

Up to 3 bar (43.5 psi)

\* **Note.** The maximum range for suspended solids measurement is dependent upon the coefficient value of the sample.

**7997-300 Turbidity Sensor****Range**

Programmable 0 — 100 FTU to 0 — 500 FTU  
and 0 to 1000mg/l (or ppm) \*

**Measurement Principle**

Transmitted light

**Measurement Characteristic**

Logarithmic based on Formazine

**Resolution**

1 FTU

**Repeatability**

Better than 1% of span

**Accuracy**

±2% of FSD  
(limited by uncertainty in Formazine standards)

**Temperature drift**

0.2 FTU/°C (0.1 FTU/°F)

**Response time**

Varies with flow rate, typically 90% step change in  
2 minutes at 1 l/min

**Flow rate**

0.5 l to 1.5 l/min

**Integral wiper cleaning system**

Programmable operational frequency every 0.25 hour, 0.5 hour,  
0.75 hour or in multiples of 1 hour up to 24 hours

**Sample operating temperature**

0 to 50°C (32 to 122°F)

**Pressure**

Up to 3 bar (43.5 psi)

**7997-400, 7997-401 Dip & 7997-405  
Flow Turbidity Sensors****Range**

Programmable 0 — 100 to 0 — 1000 FTU  
and 0 — 2000mg/l \*

**Extended Range**

0 to 2000 FTU

**Measurement Principle**

Transmitted light

**Measurement Characteristic**

Logarithmic, based on Formazine

**Resolution**

1 FTU

**Repeatability**

Better than 1% of span

**Accuracy (0 to 1000 FTU)**

±2% FSD  
(limited by the uncertainty of Formazine)

**Accuracy (0 to 2000 FTU)**

Better than ±10% of span

**Temperature drift**

0.2 FTU/°C (0.1 FTU/°F)

**Flow rate (7997-405 only)**

0.5 to 2 l/min

**Integral wiper cleaning system**

Programmable operational frequency every 0.25 hour, 0.5 hour,  
0.75 hour or in multiples of 1 hour up to 24 hours

**Sample operating temperature**

0 to 50°C (32 to 122°F)

**Dip stem length**

7997-400      1m (3.3 ft)

7997-401      2m (6.6 ft)

**Pressure (7997-405 only)**

Up to 3 bar (43.5 psi)

\* **Note.** The maximum range for suspended solids measurement is dependent upon the coefficient value of the sample.

**4670-5/500 Analyzer Models****Display****Measured value**

5-digit x 7-segment backlit LCD

**Information**

16-character, single line, dot matrix, backlit LCD

**Ranges**

Used with 7997-202/201	0 – 1 to 0 –30 NTU
Used with 7997-200	0 – 25 to 0 – 250 NTU
Used with 7997-300	0 – 100 to 0 – 500 FTU and 0 – 1000mg/l
Used with 7997-400/401/405	0 – 100 to 0 – 1000* FTU and 0 – 2000mg/l

\* 0 – 2,000 FTU with reduced accuracy

**Units of measurement**

NTU and FTU all models

mg/l on models 7997-300 and 7997-400

**Accuracy**

±0.2% of reading, ±1 digit

**Linearity**

±0.1% FSD

**Auto-clean timing**

Programmable 15min, 30min, 45min or 1hour up to 24 hours in 1 hour increments

**Environmental Data****Operating temperature limits**

–20 to 55°C (–4 to 131°F)

**Storage temperature limits**

–25 to 55°C (–13 to 131°F)

**Operating humidity limits**

Up to 95% RH non-condensing

**Power Supply****Voltage requirements**

100 to 130V, 200 to 260V, 50/60Hz

**Power consumption**

&lt; 6VA AC

**Error due to power supply variation**

Less than 0.1% for +6% –20% variation from nominal supply

**Insulation**

Mains to earth (line to ground) 2kV RMS

**Relay Outputs and Set Points****No. of relays**

Two

**Relay contacts**

Single pole changeover

Rating	250V AC 3A AC	250V DC max. 3A DC max.
Loading (non-inductive) (inductive)	750VA 750VA	30W max. 3W max.

**Insulation**

2kV RMS contacts to earth (ground)

**No. of set points**

Two

**Set point adjustment**

Programmable

**Set point hysteresis**

±1% fixed

**Local set point annunciation**

Red LED

**Retransmission****No. of retransmission signals**One fully isolated programmable 0 to 10mA, 0 to 20mA or 4 to 20mA  
Optional – second current output**Accuracy**

±0.25% FSD ±0.5% reading

**Resolution**

0.1% at 10mA, 0.05% at 20mA

**Max. load resistance**

750 (20mA max.)

**Mechanical Data****Model 4670/500**

Wall-mounting

Protection IP66/NEMA4X

Dimensions 160mm (6.30 in.) wide x 214mm (8.43 in.) high x 68mm (2.68 in.) deep

Weight 2kg (4½ lb)

**Model 4675/500**

Panel-mounting (¼ DIN)

Protection IP66/NEMA4X front

Dimensions 96mm (3.78 in.) wide x 96mm (3.78 in.) high x 191mm (7.52 in.) deep

Weight 1.5kg (3¼ lb)

Panel cut-out: 92<sup>+0.8</sup><sub>-0</sub> mm x 92<sup>+0.8</sup><sub>-0</sub> mm  
(3.62<sup>+0.03</sup><sub>-0</sub> in. x 3.62<sup>+0.03</sup><sub>-0</sub> in.)

## 9 SPARES

### 9.1 Model 7997 200 Series

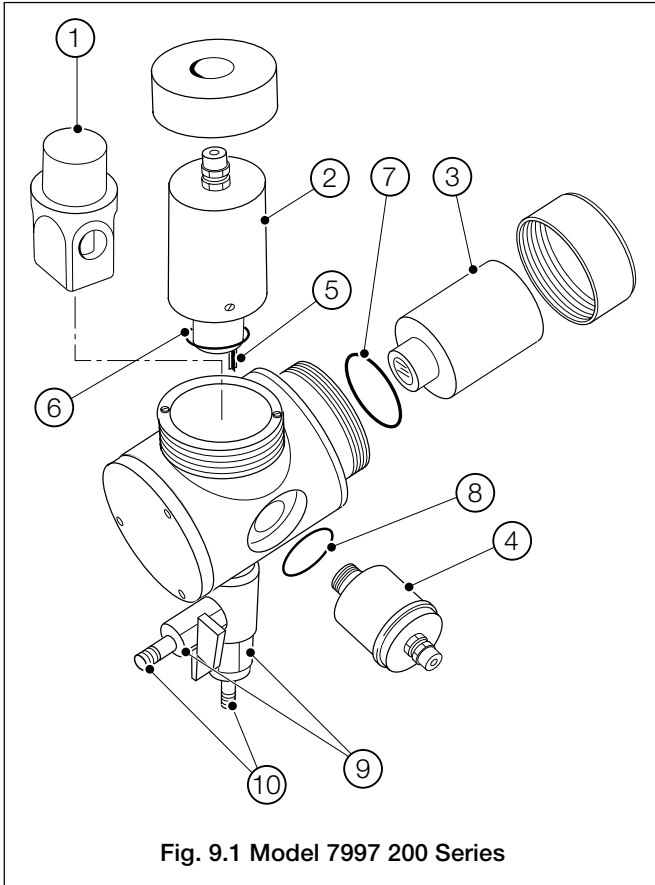

Item	Description	Part No.
1	Dry Calibration Standard Silica Gel (may be ordered separately)	0217 464
2	Cleaning Module* Cleaning Module Upgrade Kit (Upgrade from 7997 202 to 7997 201) Cell Blanking Plug (For 7997 194)	7997 080 7997 196
3/4	Emitter/Receiver Kit – Low Range (0 to 30 NTU)	7997 181
3/4	Emitter/Receiver Kit – High Range (0 to 250 NTU)	7997 182
5	Wiper Blade	7997 096
	'O' Ring Spares Kit that includes Items 6, 7 & 8	7997 009
6	'O' Ring	0211 323
7	'O' Ring	0211 319
8	'O' Ring	0211 317
9	Ball Valve 1/2 in. BSP	0216 509
10	Connector 1/2 in. BSPT	0216 510

\*7997 200 and 201 only

**Table 9.1 Model 7997 200 & 7997 201 Series Spare Parts**

### 9.2 Model 7997 300

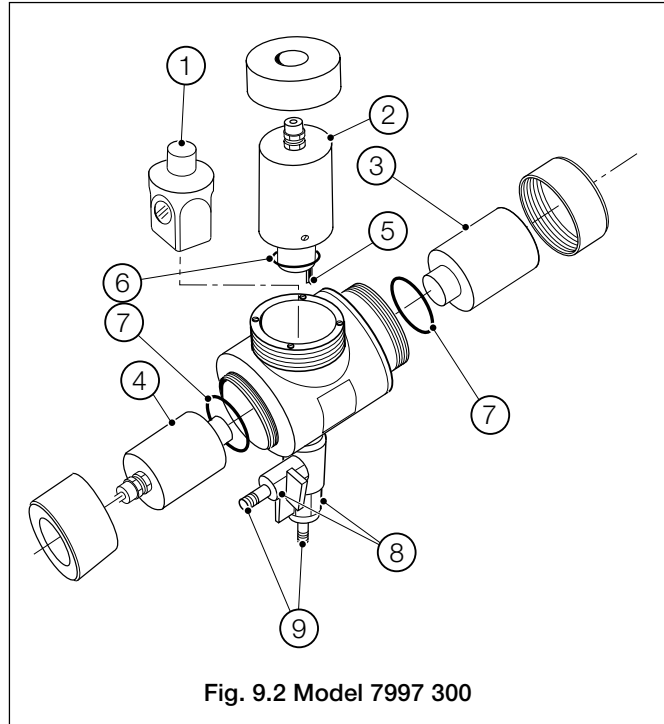

Item	Description	Part No.
1	Dry Calibration Standard Silica Gel (may be ordered separately)	0217 464
2	Cleaning Module	7997 080
3	Emitter Assembly (0 to 500 FTU)	7997 053
4	Receiver Assembly (0 to 500 FTU)	7997 091
5	Wiper Blade Assembly	7997 096
	'O' Ring Spares Kit that includes Items 6 & 7	7997 009
6	'O' Ring	0211 323
7	'O' Ring – 2 off	0211 319
8	Ball Valve 1/2 in. BSP	0216 509
9	Connector 1/2 in. BSPT	0216 510

**Table 9.2 Model 7997 300 Spare Parts**



9.3 Model 7997 400 Series

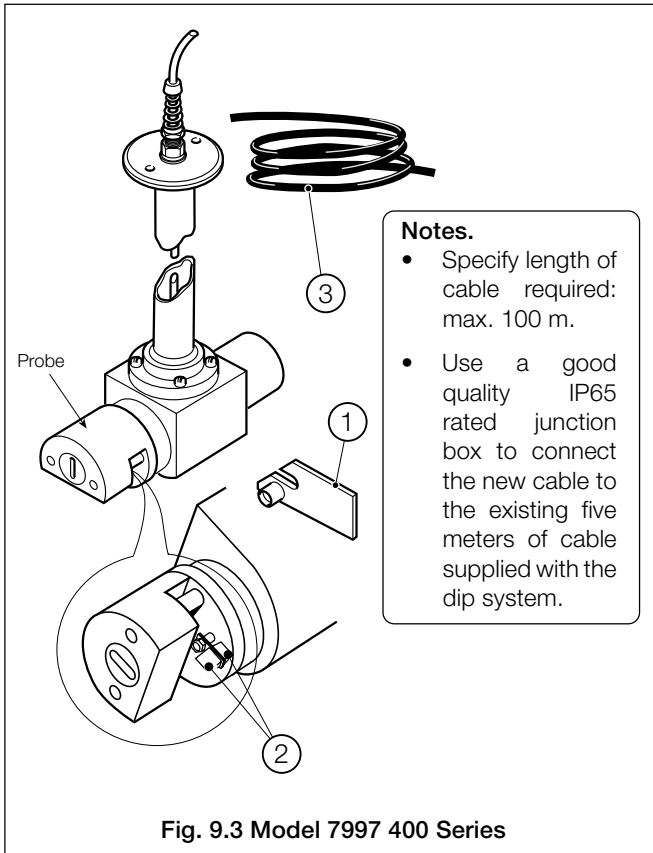

Fig. 9.3 Model 7997 400 Series

Item	Description	Part No.
1	Dry Calibration Standard Silica Gel (may be ordered separately)	0217 464
2	Wiper blades – 2 off	7997 133
3	Extension Cable (see <b>Note</b> in Fig. 9.3)	0233 828

Table 9.3 Model 7997 400 Series Spare Parts

9.4 Calibration Standards

Sensor Type	Dry Calibration Part no.	Typical value
7997 200	7997 087	50 to 150 NTU
7997 201	7997 170	0.7 to 1 NTU
7997 300	7997 165	150 to 200 FTU
7997 300	7997 166	300 to 360 FTU
7997 400 & 401	7997 160	60 to 80 FTU
7997 400 & 401	7997 161	600 to 700 FTU
7997 400 & 401	7997 162	800 to 900 FTU
7997 400 & 401	7997 163	120 to 160 FTU

Table 9.4 Dry Calibration Part Numbers

9.5 De-bubbler – Table 9.5

Item	Description	Part No.
1	'O' ring large (3 off)	0211 322
2	'O' ring small (2 off)	0211 138
3	Quick-fit Connector (2 off)	7997 511

Table 9.5 De-bubbler Spare Parts

# APPENDIX A

## A1 Principle of Operation

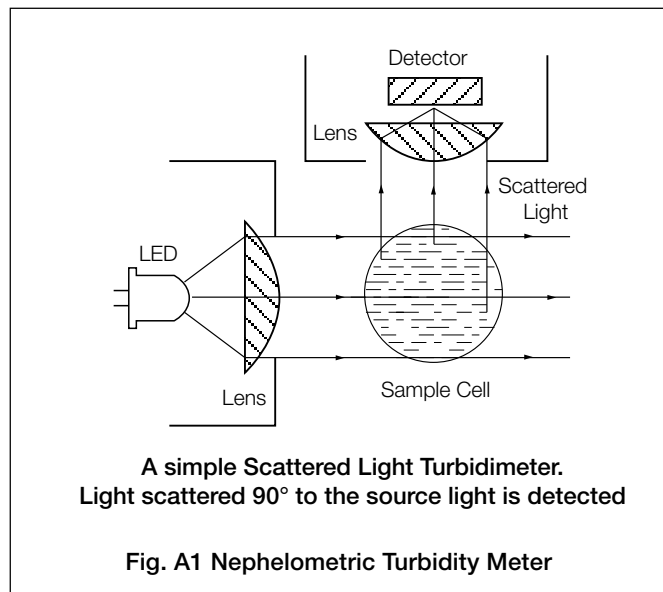

### A1.1 Nephelometric

The optical arrangement of the 7997 200 Series turbidity meters is the most widely used nephelometric design as shown in Fig. A1. This design has good sensitivity to a wide range of particle sizes from colloidal material to the large particles found in raw water.

At zero turbidity, the detector registers a near-zero output, which then rises approximately linearly with increasing turbidity. Eventually with increasing turbidity, the detector output falls as the scattered light itself is obscured and scattered before reaching the detector.

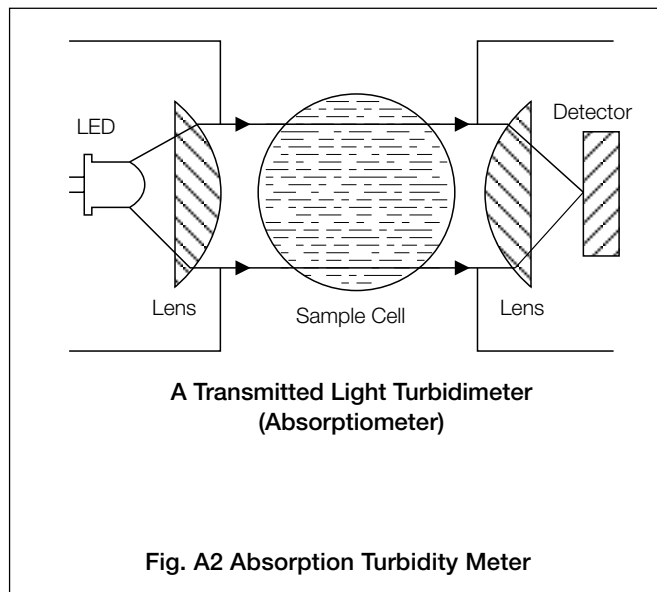

### A1.2 Absorption

7997 300, and 7997 400 Series systems use the principle of absorption through the sample and is shown diagrammatically in Fig. A2.

Absorption turbidimeters (called absorptimeters) direct a light source into the sample where particles absorb and scatter a proportion of the light. Some of the light passes straight through the sample to a detector in line with the light source where the intensity of the light is measured. The response of the detector to increasing turbidity is non linear and at zero turbidity the full light intensity reaches the detector. As turbidity increases the intensity falls until it is obscured by an opaque sample.

### A1.3 Calibration

Calibration is carried out as defined by the BS EN 27027 standard, based on formazine.

Validation checks can be made by using secondary standards, which have been calibrated against formazine.

---

## APPENDIX B

---

### B1 Determination of the Correction Factor

#### B1.1 Definition

##### Suspended solids:

The weight of solid, expressed as mg l<sup>-1</sup>, obtained by filtration through a 1 to 2 µm filter, dried to constant weight at 105°C.

##### Samples not readily filtered:

The weight of solid, expressed as mg l<sup>-1</sup>, obtained by centrifuging sample at 3200 G, dried to constant weight at 105°C.

#### B1.2 Method

Follow the calibration procedures detailed in Section 8, then carry out the following operations:

- 1) On **Set Up Parameter** page select **mg/l**.
- 2) Enter a FTU to mg/l correction factor of 1.0.
- 3) Take a note of the on-line value.
- 4) Take a grab sample for analysis to determine the 'true' suspended solid value.
- 5) Obtain the correction factor by dividing the analyzed value by the on-line value,

e.g.      if analyzed value            =        150  
              and on-line value            =        100  
              (divide 150 by 100 = 1.5)

the correction factor is 1.5.

- 6) Enter the correction factor using the  and  keys.

**Note.** If the instrument is configured for suspended solids, the calibration is still carried out as turbidity, using either the dry standard or a formazine solution.

# APPENDIX C

## C1 7997 100 Sensors

### C1.1 Description

This sensor is no longer available. It has been replaced by the 7997 201 and 7997 202 sensors. It is included here to provide information for users of existing 7997 100 sensors.

The sensor is designed to operate at very low turbidity values of less than 0.1 NTU. At these very low turbidity values it is most important that additional sources of light scattering are eliminated, i.e. gas bubbles in the sample. To minimize sample degassing, sample flow rate and line pressure must be controlled by a valve on the outlet of the flowcell and NOT on the inlet – see Fig. C2.

If the line pressure is above the flowcell limit of 3 bar, line pressure cannot be reduced before the flowcell without introducing degassing. In this case an optional debubbler (part number 7997 500) is available to eliminate the effect of gas bubbles.

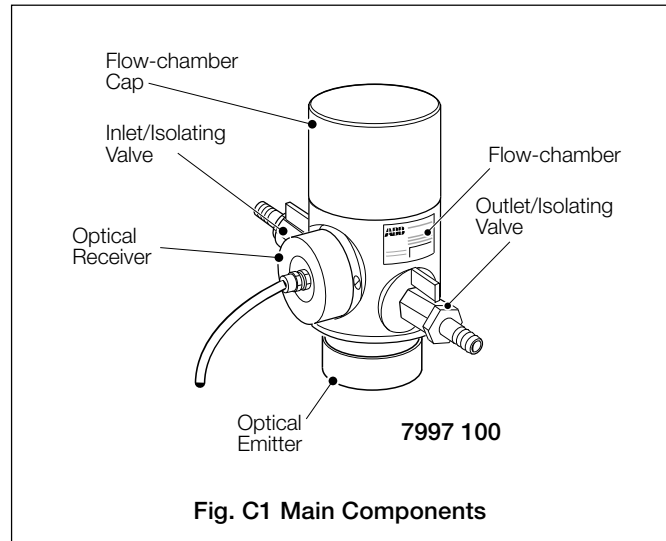

Fig. C1 Main Components

### C1.2 Flow Unit Dimensions

Model	Height	Width	Depth
7997 100	257.0	320.0	216.0

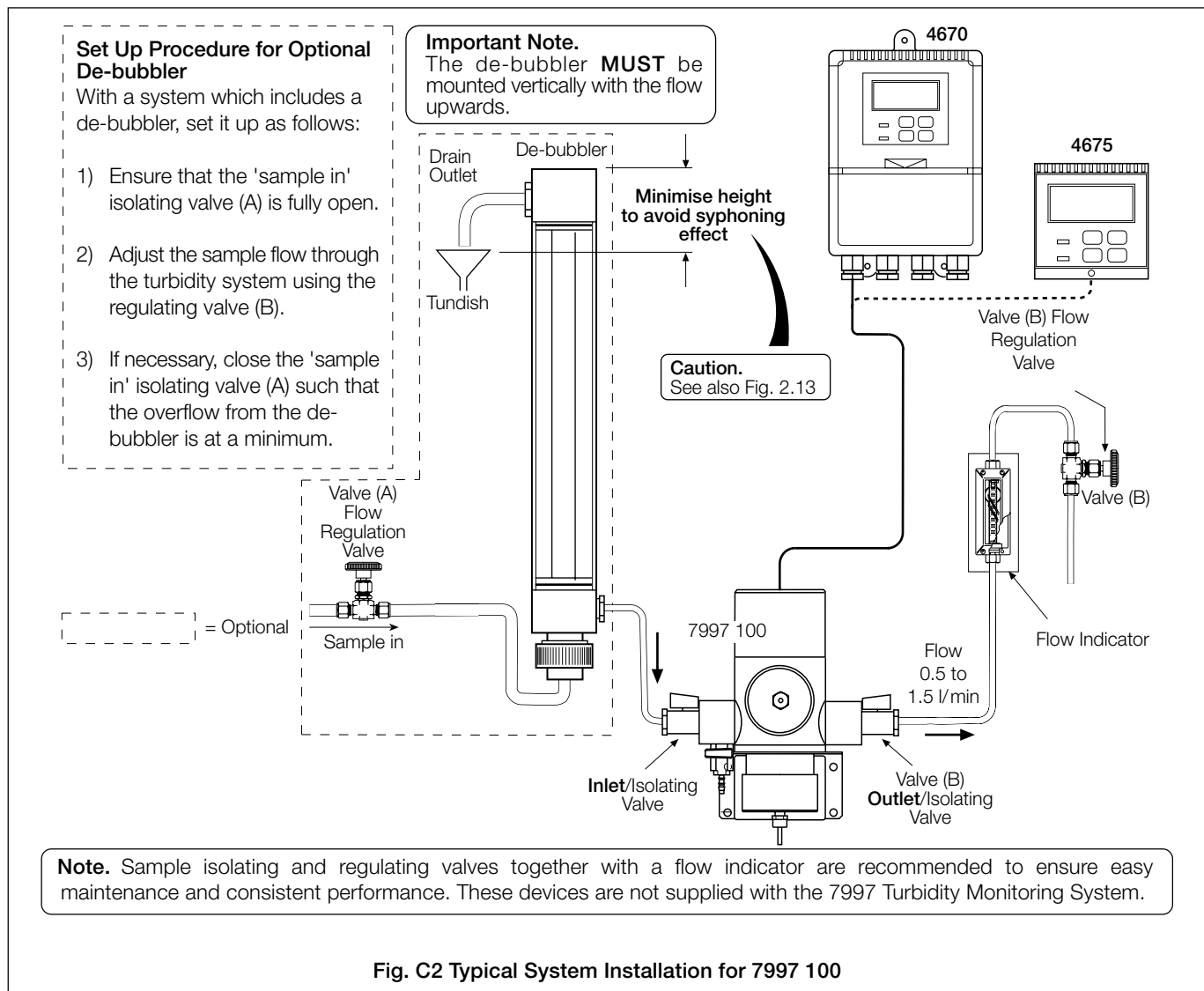
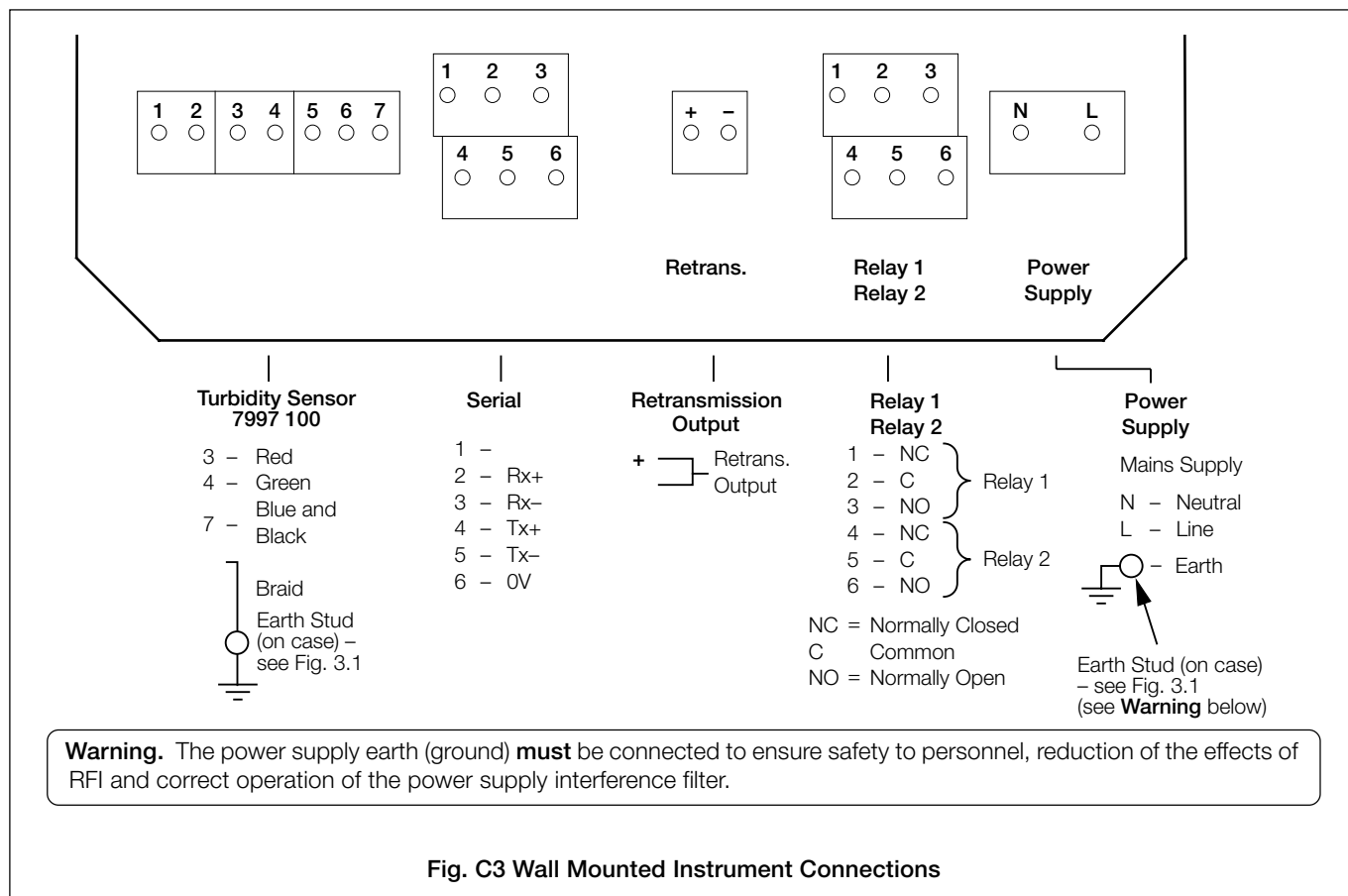

Fig. C2 Typical System Installation for 7997 100

### C1.3 Wall-mounted Instrument Connections – Fig. C3

**Note.** Refer to Fig. 3.1 for Access to Terminals.

**Caution.** Slacken terminal screws fully before making connections.



C1.4 Panel-mounted Instrument Connections – Fig. C4

**Note.** Refer to Fig. 3.2 for Access to Terminals.

**Caution.** Slacken terminal screws fully before making connections.

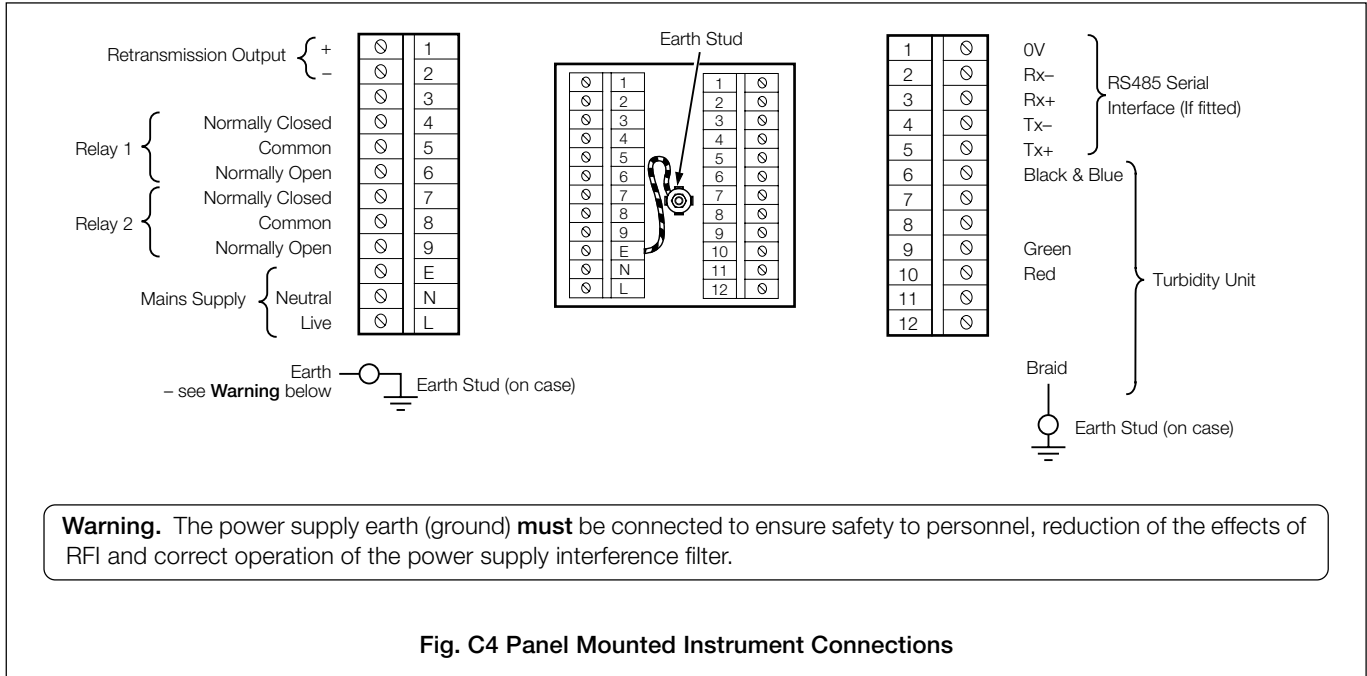

Fig. C4 Panel Mounted Instrument Connections

C1.5 Turbidity Unit Connection Box

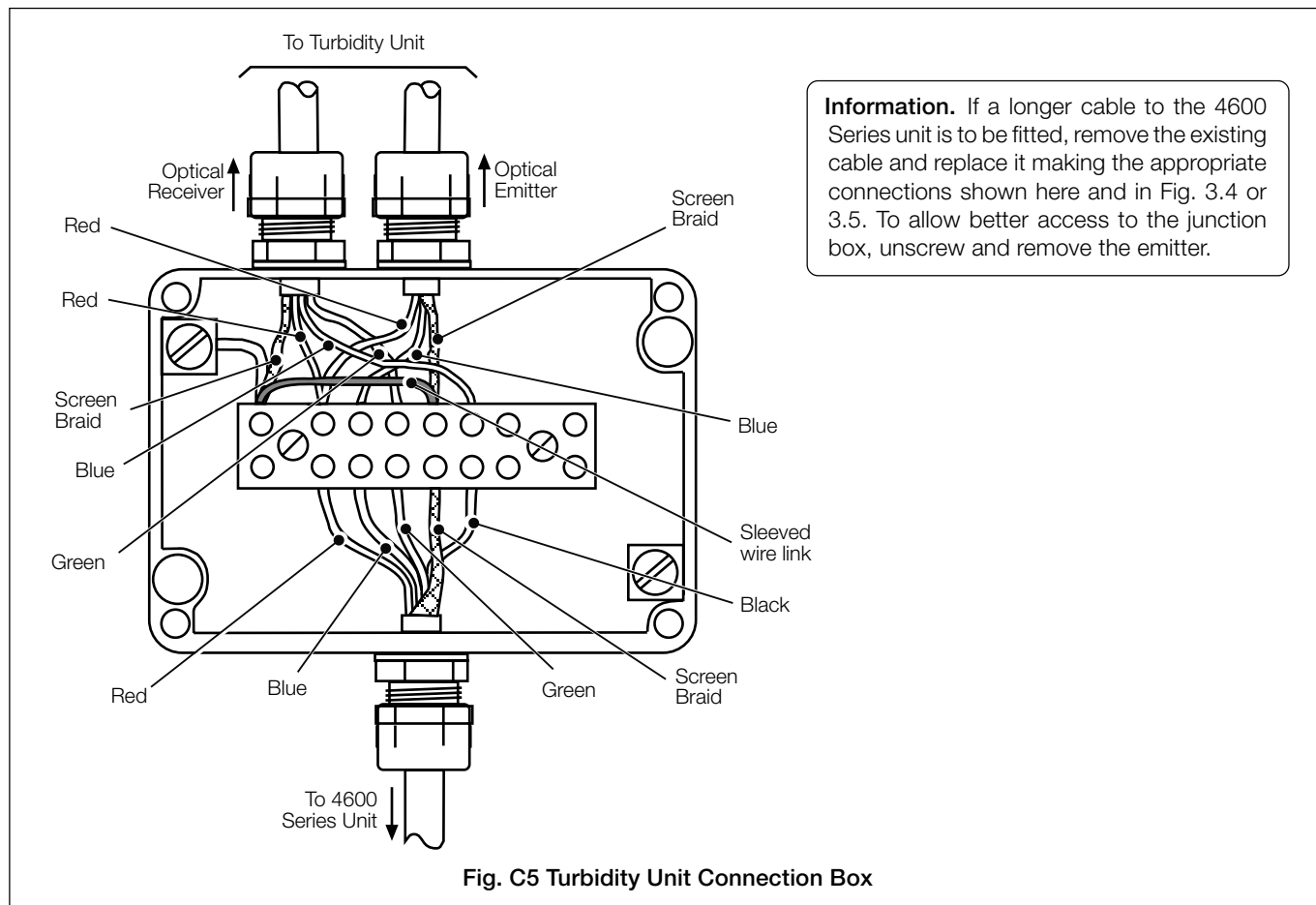

Fig. C5 Turbidity Unit Connection Box

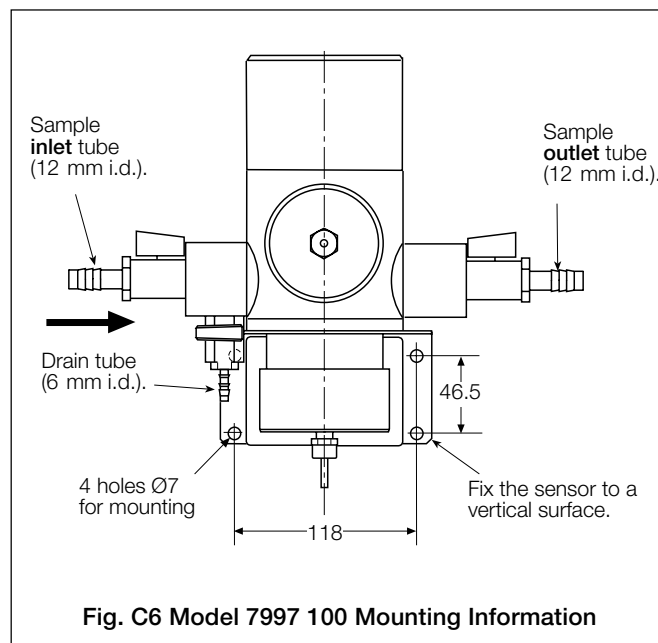
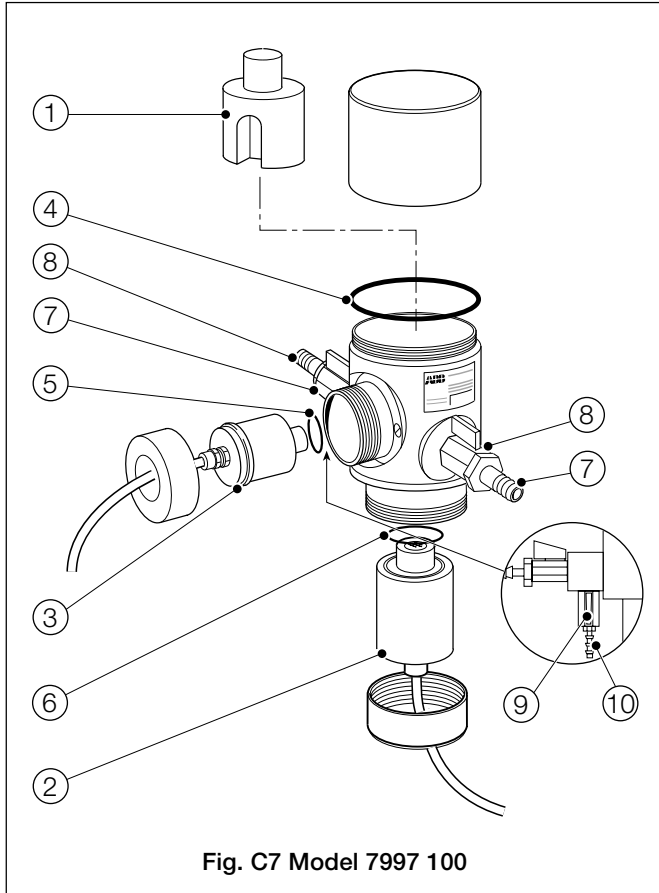

Fig. C6 Model 7997 100 Mounting Information

**C1.6 Maintenance**



**Fig. C7 Model 7997 100**

**C1.7 Spares**

Item	Description	Part No.
1	Silica Gel (may be ordered separately)	0217 464
	'O' Ring Spares Kit which includes Items 4,5 & 6	7997 010
7	Ball Valve 1/2 in. BSP	0216 509
8	Connector 1/2 in. BSPT	0216 510

**Table C1 Model 7997 100 Spare Parts**

**Sensor Cleaning**

The Model 7997/100 sensor unit is generally used on clean water samples and maintenance should be limited mainly to manual monthly cleaning of the flow chamber, under normal conditions. If there is a high turbidity breakthrough, clean the chamber immediately to ensure accurate readings.

**Calibration**

Calibration can be carried out using either a Dry Calibration Standard or Formazine Solution.

**C1.8 Specification**

Range: ..... Programmable between 0 to 1 NTU and 0 to 30 NTU.

Principle: ..... Nephelometric.

Resolution: ..... 0.1 NTU.

Repeatability: ..... Better than 1% of span.

Accuracy: .....  $\pm 2\%$  of FSD @ 25°C  
(limited by uncertainty in formazine standards).

Temperature drift: . 0.005 NTU/10°C.

Response time: .... Varies with flow rate, typically 90% step change in less than 45 seconds at 1 l min<sup>-1</sup>.

Flow Rate: ..... 0.5 to 1.5 l min<sup>-1</sup>.

Sample operating temperature: ..... 0 to 50°C.

Sample pressure: . Up to 3 bar.



---

## NOTES

---



# PRODUCTS & CUSTOMER SUPPORT

## Products

### Automation Systems

- *for the following industries:*
  - Chemical & Pharmaceutical
  - Food & Beverage
  - Manufacturing
  - Metals and Minerals
  - Oil, Gas & Petrochemical
  - Pulp and Paper

### Drives and Motors

- *AC and DC Drives, AC and DC Machines, AC Motors to 1kV*
- *Drive Systems*
- *Force Measurement*
- *Servo Drives*

### Controllers & Recorders

- *Single and Multi-loop Controllers*
- *Circular Chart and Strip Chart Recorders*
- *Paperless Recorders*
- *Process Indicators*

### Flexible Automation

- *Industrial Robots and Robot Systems*

### Flow Measurement

- *Electromagnetic Flowmeters*
- *Mass Flowmeters*
- *Turbine Flowmeters*
- *Flow Elements*

### Marine Systems & Turbochargers

- *Electrical Systems*
- *Marine Equipment*
- *Offshore Retrofit and Refurbishment*

### Process Analytics

- *Process Gas Analysis*
- *Systems Integration*

### Transmitters

- *Pressure*
- *Temperature*
- *Level*
- *Interface Modules*

### Valves, Actuators and Positioners

- *Control Valves*
- *Actuators*
- *Positioners*

### Water, Gas & Industrial Analytics Instrumentation

- *Ph, Conductivity and Dissolved Oxygen Transmitters and Sensors*
- *Ammonia, Nitrate, Phosphate, Silica, Sodium, Chloride, Fluoride, Dissolved Oxygen and Hydrazine Analyzers.*
- *Zirconia Oxygen Analyzers, Katharometers, Hydrogen Purity and Purge-gas Monitors, Thermal Conductivity.*

## Customer Support

We provide a comprehensive after sales service via a Worldwide Service Organization. Contact one of the following offices for details on your nearest Service and Repair Centre.

### United Kingdom

ABB Limited  
Tel: +44 (0)1453 826661  
Fax: +44 (0)1453 829671

### United States of America

ABB Inc.  
Tel: +1 215 674 6000  
Fax: +1 215 674 7183

#### Client Warranty

Prior to installation, the equipment referred to in this manual must be stored in a clean, dry environment, in accordance with the Company's published specification.

Periodic checks must be made on the equipment's condition. In the event of a failure under warranty, the following documentation must be provided as substantiation:

1. A listing evidencing process operation and alarm logs at time of failure.
2. Copies of all storage, installation, operating and maintenance records relating to the alleged faulty unit.

---

**ABB** has Sales & Customer Support  
expertise in over 100 countries worldwide

[www.abb.com](http://www.abb.com)

The Company's policy is one of continuous product  
improvement and the right is reserved to modify the  
information contained herein without notice.

Printed in UK (09.08)

© ABB 2008



**ABB Limited**  
Oldends Lane, Stonehouse  
Gloucestershire  
GL10 3TA  
UK  
Tel: +44 (0)1453 826661  
Fax: +44 (0)1453 829671

**ABB Inc.**  
125 E. County Line Road  
Warminster,  
PA 18974  
USA  
Tel: +1 215 674 6000  
Fax: +1 215 674 7183